

MINISTRY OF EDUCATION AND SCIENCE OF UKRAINE
ODESA STATE ACADEMY OF CIVIL ENGINEERING AND ARCHITECTURE
DEPARTMENT OF TECHNOLOGY OF BUILDING PRODUCTION

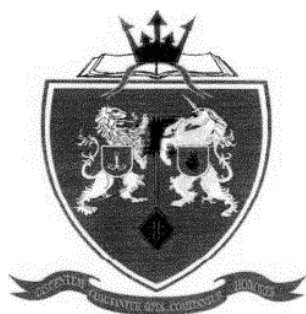

METHODICAL GUIDELINES

to complete the course project, course work in disciplines:
"Technology of construction production (special course) 2",
"Construction technology" on the topic:

DEVELOPMENT OF TECHNOLOGICAL MAP FOR THE INSTALLATION OF BITUMINOUS SHINGLES

For students in the field of knowledge 19 Architecture and Construction
specialty 192 "Industrial and Civil Engineering",
specialty 191 "Architecture and Urban Planning"
educational level bachelor of full-time and part-time study

Odesa 2022

UDC 69.024.15

"APPROVED BY"

Academic Council of the Civil Engineering Institute of the Odessa State Academy of Civil Engineering and Architecture, protocol № 10 from 1.06.2022

Authors:

Meneilyuk O. – Doctor of Technical Sciences, Professor, Head of the Department of Technology OF Building Production of OSACIA;
Nikiforov O. – Candidate of Technical Sciences, Assistant Lecturer;
Lukashenko L. – Associate Professor.

Reviewers:

Anisimov K. – Associate Professor of the Department of Hydrotechnical Structures of OSACIA.
Syvokin H. – Candidate of Philological Sciences, Associate Professor of the Department of Foreign Languages of OSACIA.

The purpose of methodical guidelines (MG) is to assist in the development of technological maps in the installation of bitumen roofing for course and diploma projects, in studying a special course of the department, and is to help students fully master the full range of knowledge in the discipline, help to understand in complex technological processes, learn to work independently.

The MG presents detailed instructions for the implementation of technological processes using modern materials and technologies.

Guidelines are intended for students majoring in specialty 192 "Construction and Civil Engineering" specialization "Industrial and Civil Engineering", specialty 191 "Architecture and Urban Planning" educational level "Bachelor", students of advanced training and retraining of specialists, graduate students and teachers.

Responsible for the issue:

Head of the Department of Technology of Building Production,
Doctor of Technical Sciences, Professor Meneilyuk O.

CONTENT

CONTENT	3
INTRODUCTION	4
1 MAIN FACTORS AFFECTING THE CHOICE OF ROOFING SYSTEM.....	5
2 CONTENT AND DESIGN OF TECHNOLOGICAL MAP	9
3 STRUCTURE OF TECHNOLOGICAL MAP.....	12
3.1 Scope	12
3.2 Organization and technology of work.....	12
3.3 Calculation of labor costs and wages	29
3.4 Calendar schedule of works	42
3.5 Tables of material and technical resources need.....	51
3.6 Requirements for quality and acceptance of works	53
3.7 Safety and labor protection, environmental and fire safety	62
3.8 Technical and economic indicators	64
REFERENCES	66
APPENDIX A. Educational video clips for creating calculations and schedules	68
APPENDIX B. Example of a graphic part of a technological map	69
APPENDIX B. Example of the design of the title page	70
APPENDIX D. Variants of tasks	71
APPENDIX D. Table of self-assessment of technological map performance.....	76

INTRODUCTION

Cheap and reliable waterproofing materials, in particular for roofs, are becoming increasingly important in modern construction. One such material is bituminous shingles. It combines the reliability of seamless insulating materials with low cost of components and a relatively simple process of installation. At the same time bituminous shingles allow to reach high aesthetic standards as this roofing can be put on rafter systems of various configurations and has a set of options of coloring.

Objects equipped with a bituminous shingles roof are in great demand in the real estate market. Intensive use of such roofs began after the emergence of appropriate materials that can withstand the load, and are best adapted to different climatic conditions.

1 MAIN FACTORS AFFECTING THE CHOICE OF ROOFING SYSTEM

For long-term service and operation of the roof, it is important to properly arrange all the layers of the roof structure, the so-called roofing "pie". The purpose of the roof will calculate the load on the roof, as well as selection of materials for construction with the appropriate properties and characteristics. Proper selection of roofing pie, materials and quality installation can guarantee the service life of the roof for 30-50 years.

Roofing pie materials must withstand all emerging loads on the roof and not collapse. The load on the materials in the roof can reach 0.4 t/m^2 , so the strength requirements for materials in such roofs are increased.

The effect of solar radiation on the roof leads to premature "aging" and destruction of materials. All materials that are exposed to solar radiation must be stable to it. Loads and effects acting on the roof are shown in Fig. 1.1.

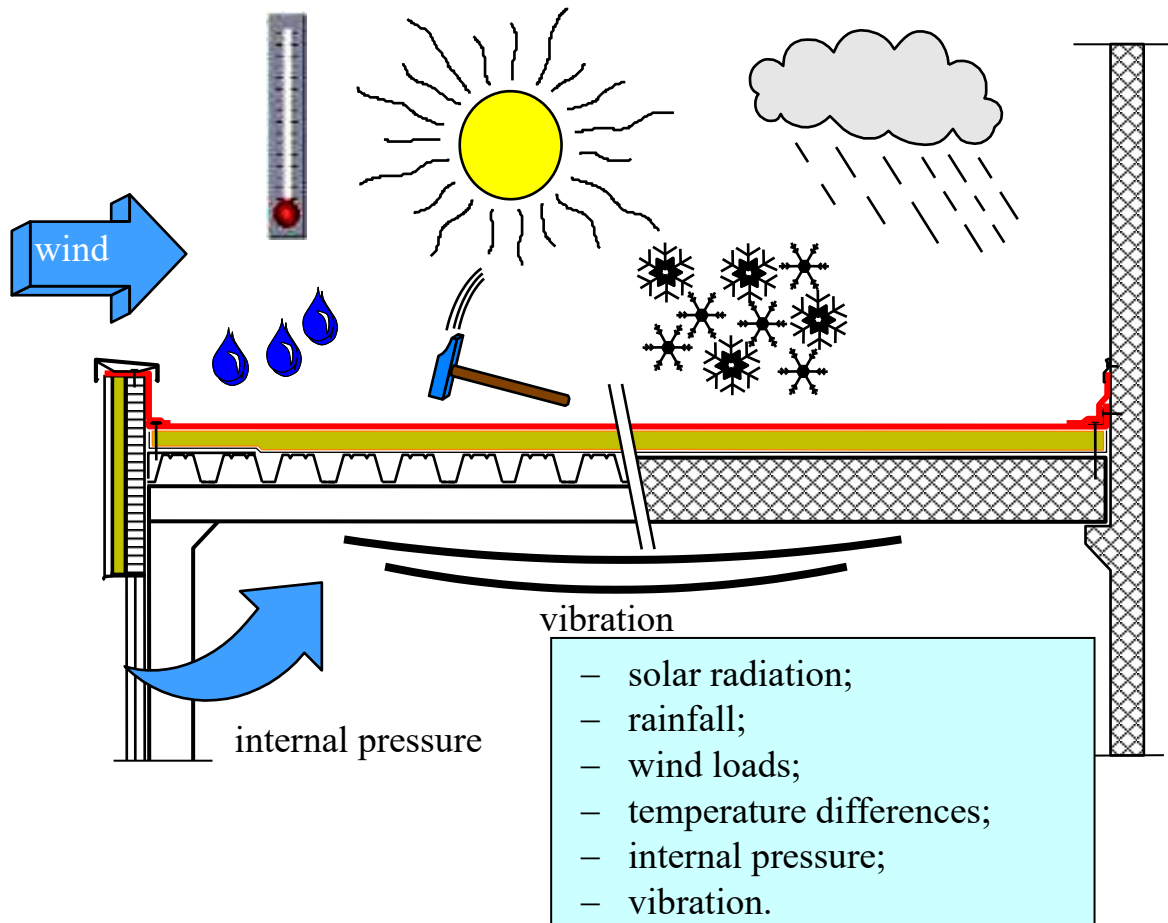

Figure 1.1 – Loads and effects on the roof

Waterproofing on the roofs was placed for a long time over the insulation from moisture to protect it. Now such roofs are called traditional. The use of low-water insulation materials on the roof allowed the waterproofing to be placed under it. Such

roofs are called inverted. This method of laying materials allows to increase the service life of the waterproofing carpet.

Depending on the material of the coating, roofs are divided into flat (slope 2.5%) and sloping (slope more than 2.5%). Classification of roofing is given in Fig. 1.2.

The installation of the roof begins with the installation of the rafter system. Depending on the design of the roof, some elements of the rafter system may change. The roof of the building consists of the following elements (Fig. 1.3): inclined planes, called slopes (1), which are based on rafters (2) and lattice (3). The lower ends of the rafter legs rest on the tying beam (mauerlat) (4). The intersection of the slopes forms inclined (12) and horizontal ribs, which are called ridges (5). The ridge is the junction of two slopes at the top. The intersection of the slopes that form the inner corners create grooves (6). These are the most vulnerable places on the roof, because snow accumulates there in winter and rainwater in summer. The edges of the roof over the walls of the building are called eaves (7) (located horizontally, protruding beyond the contour of the outer walls) or gable overhangs (11) (located at an angle). Water flows down the slopes to the wall gutters (8) and is discharged through the water intake funnels (9) into the drainage pipes (10) and further into the storm sewer.

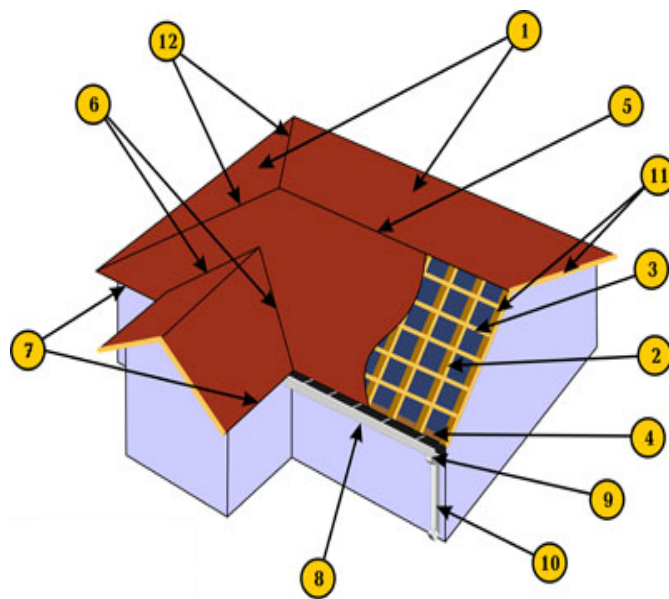

Figure 1.3 – The main elements of the roof:

- 1 – slopes; 2 – rafters; 3 – lattice; 4 – mauerlat; 5 – ridge; 6 – groove; 7 – eaves;
- 8 – wall gutter; 9 – water intake funnel; 10 – drain pipe; 11 – gable overhangs;
- 12 – inclined ribs

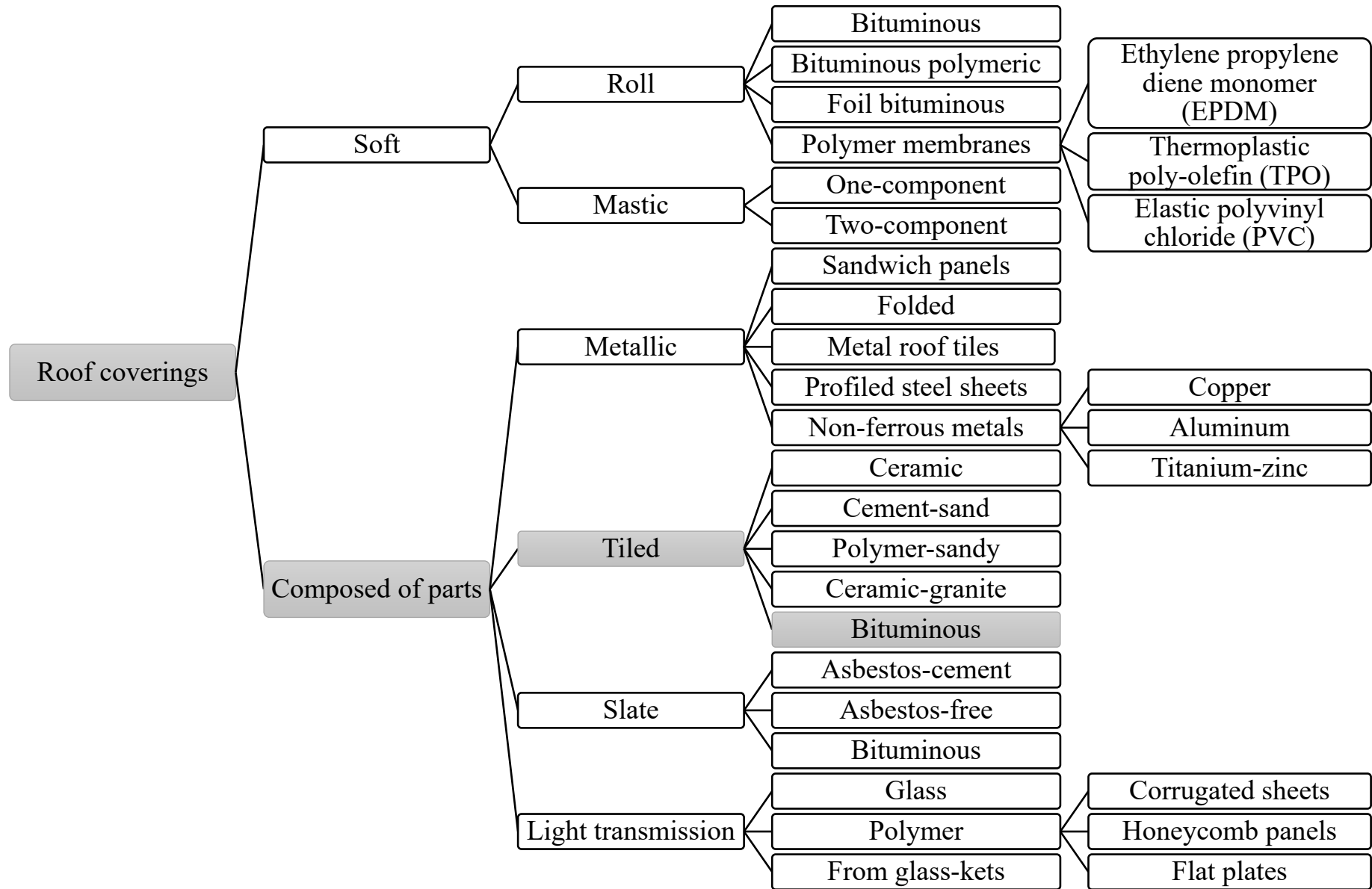

Figure 1.2 – Classification of roofing

There are two types of rafter systems – leaning and hanging (Fig. 1.4). The leaning rafter system is used in houses with internal load-bearing walls or columns located in 5-6 m, which can be supports for rafter structures. Hanging rafter system is used in houses with gabled roofs, where there are large spans and no internal load-bearing walls. It is a stable geometric figure – a triangle consisting of two rafter legs (upper belt) and puffs (lower belt), rigidly connected to each other in the truss.

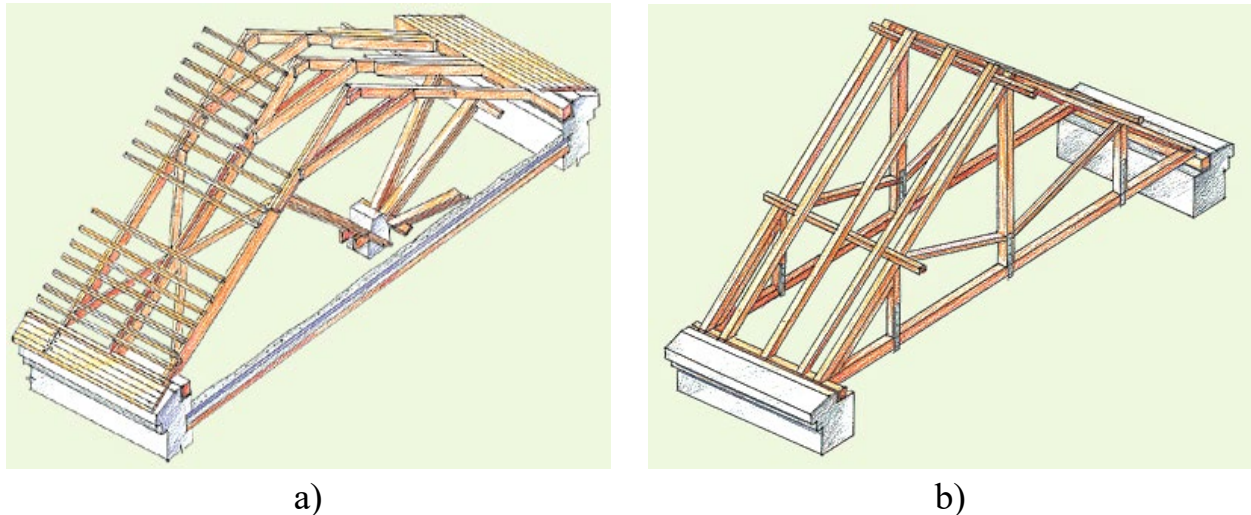

Figure 1.4 – Leaning (a) and hanging (b) rafter system with additional middle support

Soft bituminous shingles are often called roof tiles. It is a small flat sheets, with curved cutouts on one edge (usually one sheet mimics 3-4 tiles). This material, on the one hand, is artificial and, on the other hand, it can be fully attributed to the group of "soft roofs", as its structure and components are close to roll materials. In addition, like all other soft roof materials, it performs only a protective (waterproofing) function.

Bituminous shingles can be used on roofs with a slope of at least 10° , and with slopes from 10° to 18° requires the installation of a special underlay carpet. The maximum slope is not limited, you can cover even the vertical sections of the walls adjacent to the roofs.

Bitumen tiles are used both for the installation of new roofs and for the reconstruction of old ones (applied directly on top of damaged coatings prepared in a certain way). In the case of soft tiles on top of bituminous coatings, the latter perform the function of the lower lining carpet.

2 CONTENT AND DESIGN OF TECHNOLOGICAL MAP

The technological map (TM) consists of a settlement and explanatory note and a graphic part. Technological maps are the main part of organizational and technological documentation. They regulate the means of technological support, the rules of technological processes in the construction and reconstruction of buildings and structures.

The settlement and explanatory note of 20-25 pages is made on one side of a sheet of standard A4 format, the graphic part – on a sheet of A1 format. The title page of the note is drawn up in the prescribed form (Appendix B). The content of the note, introduction and assignments for the course project or work are placed after the title page.

The introduction summarizes the general provisions of the complex of works. The main part of the note provides diagrams, tables, figures, graphs and references to the sources used. At the end of the explanatory note is a list of used information sources and regulations.

The note must be prepared in accordance with State Standard of Ukraine 3008-2015 [1]. Pages are numbered in Arabic numerals, covering appendices. The page number is placed on the right in the upper corner of the page without a dot at the end. The title page is included in the general page numbering. The page number is not affixed to the title page. The pages with the figures and tables are covered by the general numbering of the pages.

Sections, subsections, paragraphs, sub-paragraphs are numbered in Arabic numerals. Sections are numbered within the essence and are denoted by Arabic numerals without a full stop, starting with the number "1". The subsections number consists of the relevant section number and the subsections number separated by a full stop. There should not be put a full stop after the subsections number, for example, 1.1, 1.2, etc. Paragraphs are numbered in Arabic numerals within each section or subsection. The paragraphs number consists of the section number and the subsection number and the paragraph number, which are separated by a full stop. There should not be put a full stop after the paragraph number, for example, 1.1, 1.2 or 1.1.1, 1.1.2, etc.

The figure is submitted immediately after the text where it is first referenced, or as close as possible to it on the next page, and if necessary – in the appendices to the note. If the drawings were not created by the author of the note, submitting them in the note must be complied with the requirements of current legislation of Ukraine on copyright. Figures are numbered in Arabic numerals, except for the figures in the appendices. Figures are allowed to be numbered within each section. In this case, the figure number consists of the section number and the sequence number of the figure in this

section, which are separated by a full stop, for example, "Figure 3.2" – the second figure of the third section.

Numerical data should be formatted as a table according to the form provided on Fig. 2.1.

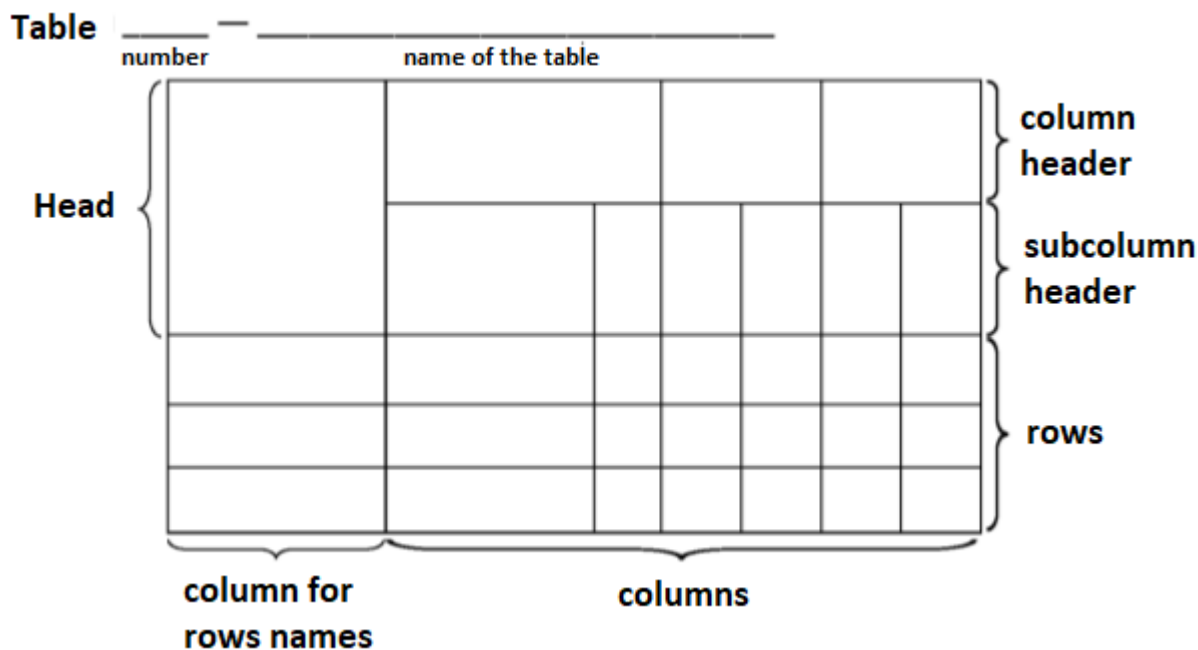

Figure 2.1 – Design of the table

The table is submitted immediately after the text in which it is mentioned for the first time, or on the next page. Each table should be referenced in the text of the note with its number. The tables are numbered in Arabic numerals, except for the tables in the appendices. Tables may be numbered within a section. In this case, the table number consists of a section number and a table sequence number, separated by a full stop, for example, "Table 2.1" – the first table of the second section. If the rows or columns of the table go beyond the format of the page, the table is divided into parts, placing one part under another or side by side, or part of the table on the next page. Head and side of the table are repeated in each its part. If the table is divided into parts, it is allowed to replace its head or sidewall with the numbers of columns or rows, respectively, numbering them in Arabic numerals in the first part of the table. The word "Table" is given only once above the first part of the table. "Continuation of table ____" or "End of table ____" without repeating its name is printed above the other parts of the table from the paragraph.

The explanatory note should include the developed technological map in accordance with the task, the structure and composition of which are described in section 3 of the MG. The note should contain the following sections:

1. Scope (subsection 3.1 of MG).
2. Organization and technology of works (subsection 3.2 of MG).
3. Calculation of labor costs and wages (subsection 3.3 of MG).
4. Calendar schedule of works (subsection 3.4 of MG).
5. Tables of material and technical resources needs (subsection 3.5 of MG).
6. Requirements for quality and acceptance of works (subsection 3.6 of MG).
7. Safety and labor protection, ecological and fire safety (subsection 3.7 of MG).
8. Technical and economic indicators (section 3.8 of MG).

The graphic part is executed on one sheet of A1 format, which shows:

1. Scope of the technological map.
2. Scheme of production of works: the plan of object with breakdown on captures, schemes of movement of workers and mechanisms.
3. Technological schemes, sequence of technological operations
4. Calendar schedule of works
5. Guidelines for quality control and acceptance of works.
6. The need of material and technical resources
7. Technical and economic indicators of the technological map

The recommended layout of information on the sheet of the graphic part is given in Fig. 2.2.

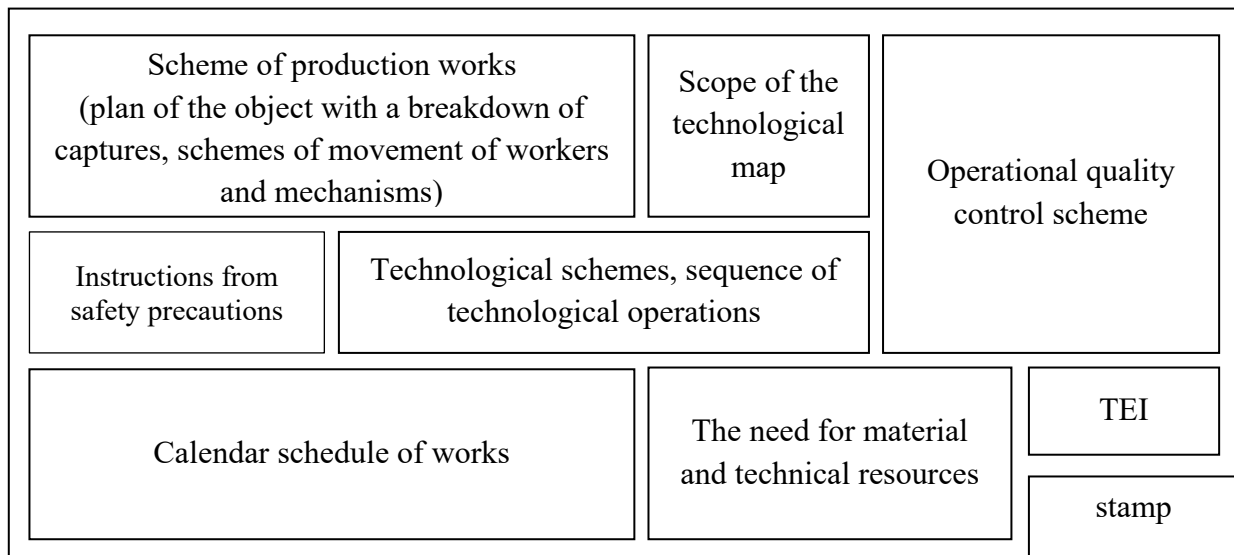

Figure 2.2 – Layout of materials on the sheet of the graphic part

3 STRUCTURE OF TECHNOLOGICAL MAP

Technological maps are the main part of organizational and technological documentation. They regulate the means of technological support, the rules of technological processes in the construction and reconstruction of buildings and structures.

The technological map should consist of the following sections:

1. Scope.
2. Organization and technology of works.
3. Calculation of labor costs and wages.
4. Calendar schedule of works.
5. Tables of material and technical resources needs.
6. Requirements for quality and acceptance of works.
7. Safety and labor protection, ecological and fire safety.
8. Technical and economic indicators.

3.1 Scope

In this section it is necessary to indicate the binding of technology and organization of work to specific materials and conditions of work on the construction site in accordance with the task.

These methodological guidelines present the basic requirements necessary for the preparation of technological maps for the installation of bitumen roofing.

3.2 Organization and technology of work

3.2.1 Erection of structural elements of a pitched roof

The first thing to create a load-bearing wooden roof structure is to lay mauerlat on the longitudinal external load-bearing walls. Most often, mauerlat is a support beam with a cross section of 150×150 mm or a log sawn into two layers, fastened to the wall of the building with anchors, laying a strip of waterproofing material under it.

Then the rafter legs (rafters) are installed which rest on the racks. The upper ends of the rafters are attached to the ridge board or overlapped with overlays, and the lower end is attached to the mauerlat brackets, as well as twists to the walls of the building. Twists are a piece of thick wire, one end of which is attached to the rafter leg, and the other - to the crutch, driven into the seam of masonry at a distance of 300 mm from the upper edge of the wall. This technique will help maintain the integrity of the roof in strong gusts of wind.

The issue of reliable and strong connection of wooden parts (beams, beams, boards, etc.) is very important in the construction of the rafter system. Recently, the problem of reliable connection of wooden structural elements has been solved by using metal toothed (nail) plates (Fig. 3.1).

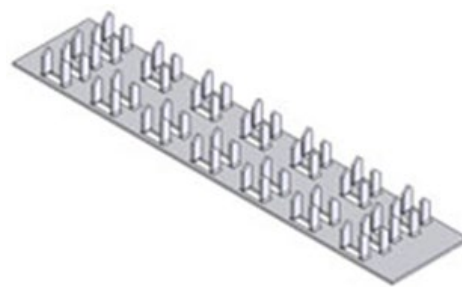

Figure 3.1 – Metal nail plate

The design feature of nail plates is that all teeth have a common monolithic base, which eliminates the possibility of their mobility and oscillation. The base is a connection of two structural parts. Mass construction of wooden structures using metal toothed (nail) plates originates in North America. And now connecting plates are widely used throughout Europe.

With the help of industrial rafter structures on the basis of toothed plates, there can be build almost any type of roof, attic, attic, roof windows, etc. Roofs with the use of nail plates are used in all types of buildings. These are, for example, residential buildings, industrial, agricultural, sports and commercial buildings. Indispensable plates are also in the reconstruction of buildings and flat roofs. In addition to rafter structures, this technology can be used to make wall panels, lattice frames, formwork for concrete structures, spans made entirely of wood. It is possible to create farms with a span of more than 30 meters without internal supports (for example, tennis courts). Examples of the use of nail plates in the installation of elements of the rafter system are shown in Fig. 3.2 (a) and (b).



a)



b)

Figure 3.2 – Examples of the use of nail plates: a – fastening of rafters and mauerlat; b – connecting nail plates on the skate

All sizes of rafter legs, lattice and other elements are determined during design by structural calculation. The width of the rafter boards is usually 50 mm, height – 150, 180 and 200 mm.

Puffs or rafters lead beyond the line of the outer wall of the house to form an overhang that protects the wall from getting wet. The size of the eaves should be at least 550 mm. If the length of the rafters is insufficient to form an overhang, they are extended.

3.2.2 Installation of steam, hydro and thermal insulation of the roof

After installing the rafter structure of the roof, the next stage is the creation of a roofing "pie". One of the most important rules is that the vapor permeability of all layers of the "pie" in the direction from the inside to the outside should increase. Then the roof will be able to breathe, and moisture will not accumulate in the roof structures and materials.

The thermal insulation of the pitched roof should be protected with a windproof vapor-permeable material from the side of the ventilated air layer. This type of material includes so-called "breathable" windproof films or other polymeric nonwovens with a density of 65-130 g/m², or on an organic basis with a density of at least 130 g/m², treated with bitumen. The vapor permeability of windproof films must be at least 150 g/m² for 24 hours.

Installation of windproof film can be performed in two directions depending on the slope of the roof: up to 1:5 – in the direction (along) the slope, more than 1:5 – parallel to the slide. The canvases overlap (150 mm). Preliminarily, the canvases are fixed with stainless (galvanized) nails with a wide cap. The final fixing is performed with wooden bars 50x50 mm.

To remove moisture from thermal insulation and wooden structures, it is necessary to ventilate the roof. To do this, the air gap between the layers of thermal insulation and the lattice of at least 50 mm must be connected to the outside air in the cornice and ridge sections. Schemes of ventilation of the attic space are given in Fig. 3.3.

To avoid the formation of condensate from the cold attic on the lattice surface, natural ventilation of the attic through the inlet and outlet openings (exhaust shafts, auditory windows, etc.) must be provided. The total area of each of them is taken not less than 1/300 of the area of the horizontal projection of the roof. The air inlet is provided by installing cracks on the lower surface of the eaves with a total width of at least 20 mm when lined with board, and when lined with siding – by using plastic or aluminum spotlight perforated slats.

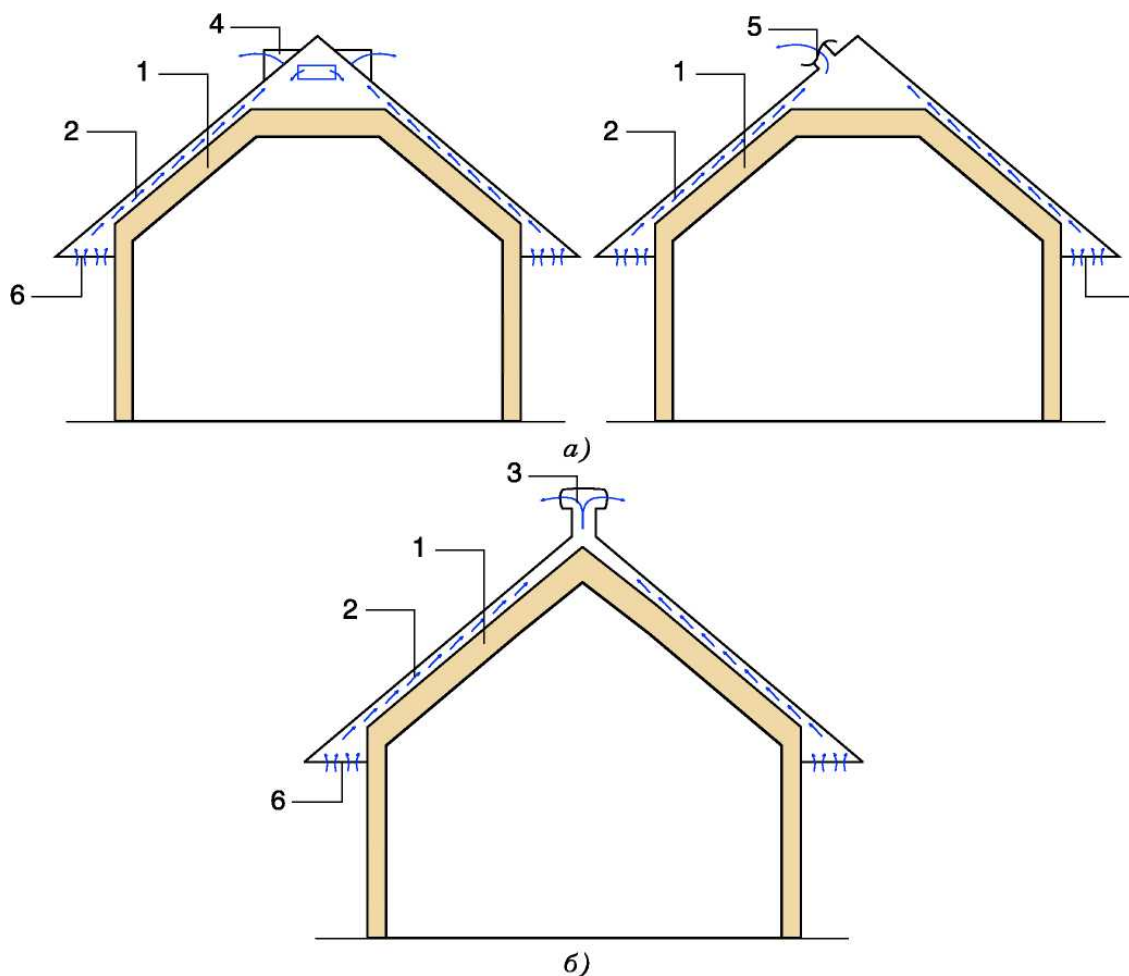

Figure 3.3 – Scheme of ventilation of the attic space: a) cold attic; b) attic floor (1 – insulation; 2 – ventilation duct 50 mm; 3 – ridge exhaust element (deflector); 4 – auditory window; 5 – roof exhaust element (deflector); 6 – slots for air inlet)

Exhaust ventilation outlet is provided (at a distance of not more than 1 m from the ridge) from the cornice to the skate for the exit of air from the attic space, circulating under the action of the pressure difference:

- ventilation grilles located on the gables;
- ridge exhaust elements – deflectors;
- sloping exhaust elements – deflectors.

To prevent the penetration of internal and external moisture under the roof during the installation of the roof, it is necessary to create ventilation gaps and use waterproofing vapor-permeable film. The film is laid on the rafters, starting from the cornice to the ridge of the roof, while overlapping 100-150 mm and allow the film to sag between the rafters (approximately 20 mm); then the film is sealed overlap with the gluing of the joints with adhesive tape (Fig. 3.4 (a) and (b)).

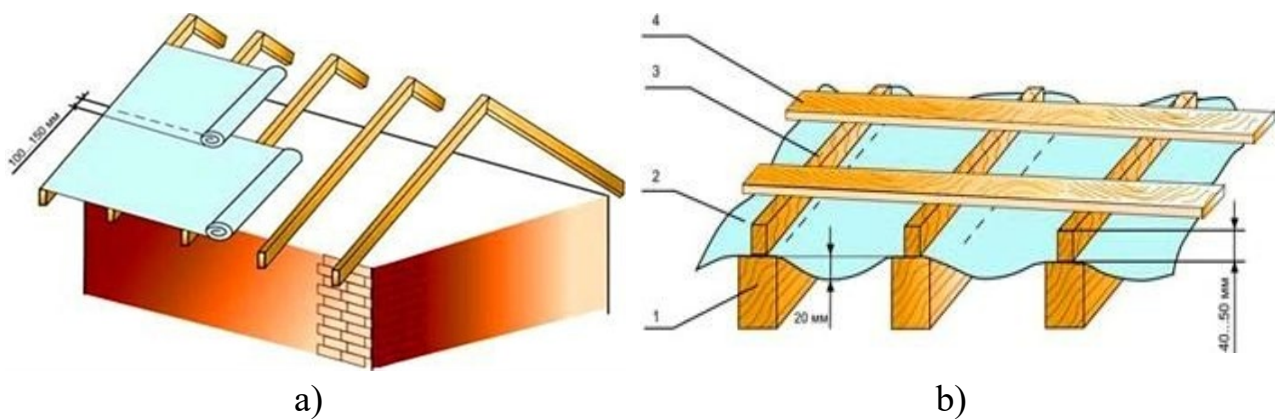

Figure 3.4 – Examples of installation of steam and waterproofing: a – laying of waterproofing vapor barrier film on the rafters; b – laying of waterproofing and lattice (1 – rafter leg; 2 – waterproofing film; 3 – bar lattice beam; 4 – lattice)

A counter-lattice is mounted on top of the vapor-permeable film. It is mounted from bars with a cross section of 50×50 or 60×60 mm, which are mounted along the rafters, repeating their pattern. The lattice performs a very important function – it forms a ventilation gap between the waterproofing and insulation. Proper organization of ventilation allows to remove excess moisture in the attic space, avoid rotting materials and fungus.

Vapor barrier of polyethylene, reinforced fabric is laid inside the attic space, on the inside of the insulation. Between the rafters lay thermal insulation material in several layers with overlapping seams. It is desirable that its thickness is less than the height of the rafters. Insulation prevents heat loss through the roof structure. It is recommended to use environmentally friendly mineral wool boards with low thermal conductivity and a density of at least 35 kg/m³.

Windproof and waterproofing film (a membrane with a certain fiber structure) is laid on the counter-lattice outside of the insulation. This material works like a nipple: it allows vapors to enter the insulation from the inside of the room, but does not allow moisture from the outside of the insulation layer.

In addition, due to the thickness of the rafters and the presence of a counter-lattice on both sides of the insulation a gap for ventilation of 20-30 mm is created. This means that atmospheric moisture that enters the attic space, or water vapor from inside the room will be easily blown out, and the wooden roof structure will not be affected by moisture.

There are recommended effective non-combustible mineral wool boards with a density of 30-140 kg/m³ with low thermal conductivity and low compressibility as a heat-insulating layer of pitched roofs.

The thickness of the insulating material is calculated according to the current State Standard of Ukraine B B.2.6-189: 2013 "Methods of choosing thermal insulation material for building insulation" [2] based on energy saving conditions, operating conditions of the premises and humidity zones.

3.2.3 Arrangement of roofing "pie"

Roofing works are performed in the following order. First, a solid lattice is arranged. Then the eaves are covered with roofing material and grooves are installed. Then the coating is laid on the grooves and auditory windows, paying special attention to the places of their connection with the slope of the roof. The next stage is the arrangement of the collar around the through openings of the roof. From the side of the ridge the sheet is wound under the roof, and from the side of the cornice – on top of it, forming a collar. After that, the slopes of the roof are covered, which is done from right to left and from bottom to top. The final stage is the installation of a drainage system.

In order to install a soft tile roof, in addition to ordinary tiles, you also need various additional and component elements. These are cornice strips, ridge elements (with ventilation holes), ventilation pipes, vacuum fans (for ventilation of the roof structure or upper floor), rolled materials for the lower carpet, roofing nails or hooks, etc.

The constructive and technological scheme of the installation of a roof from a bituminous tile is presented on Fig. 3.5.

Roofing materials such as soft bitumen roofing and flat asbestos-cement slates require the installation of a solid lattice. To do this, chipboard or moisture-resistant plywood is used, which should be laid with gaps to compensate the linear expansion of materials during temperature changes. Backing carpet is laid under the soft tile on top of solid patching, which evens out the roof surface and acts as a waterproofing during the installation of roofing material. As such a carpet, there can be used a material based on fiberglass, impregnated with modified bitumen. This allows the underlying carpet to maintain elasticity, resistance to temperature changes, excellent waterproofing properties even at low temperatures.

Soft shingles, like all bituminous materials, consists of several layers. Different types of soft shingles may differ in structure, depending on the method of installation and the desired decorative effect.

The basis of bituminous shingles is fiberglass or fiberglass with oxidized or modified bitumen applied on both sides. The front surface is a colored stone or mineral crumb, which gives the materials a variety of color shades and protects against climatic influences, thus ensuring a long period of operation. There can be applied bituminous

adhesive stains on the front surface designed for gluing shingles to each other when laying in exterior aspect (in the absence of an adhesive layer on the underside of the shingles).

The underside of the shingles is either completely covered with a layer of quartz sand, or a layer of self-adhesive modified bitumen, protected with a special film. For roofs with a small slope or a base to which it is impossible to fasten shingles by nails, completely self-adhesive shingles are applied.

A number of companies use copper sheets for the front layer. This increases the cost of the product, but provides additional design opportunities. Soft tile, veneered with copper sheet, has a slightly different structure from conventional bitumen tiles. The shingle consists of 8 layers: adhesive strip, copper foil, two layers of modified bitumen, two layers of fiberglass, lightweight coating and protective film. Shingles covered with copper sheet can be both scaly and rectangular. The structures of different bituminous shingles are shown on Fig. 3.6 and 3.7.

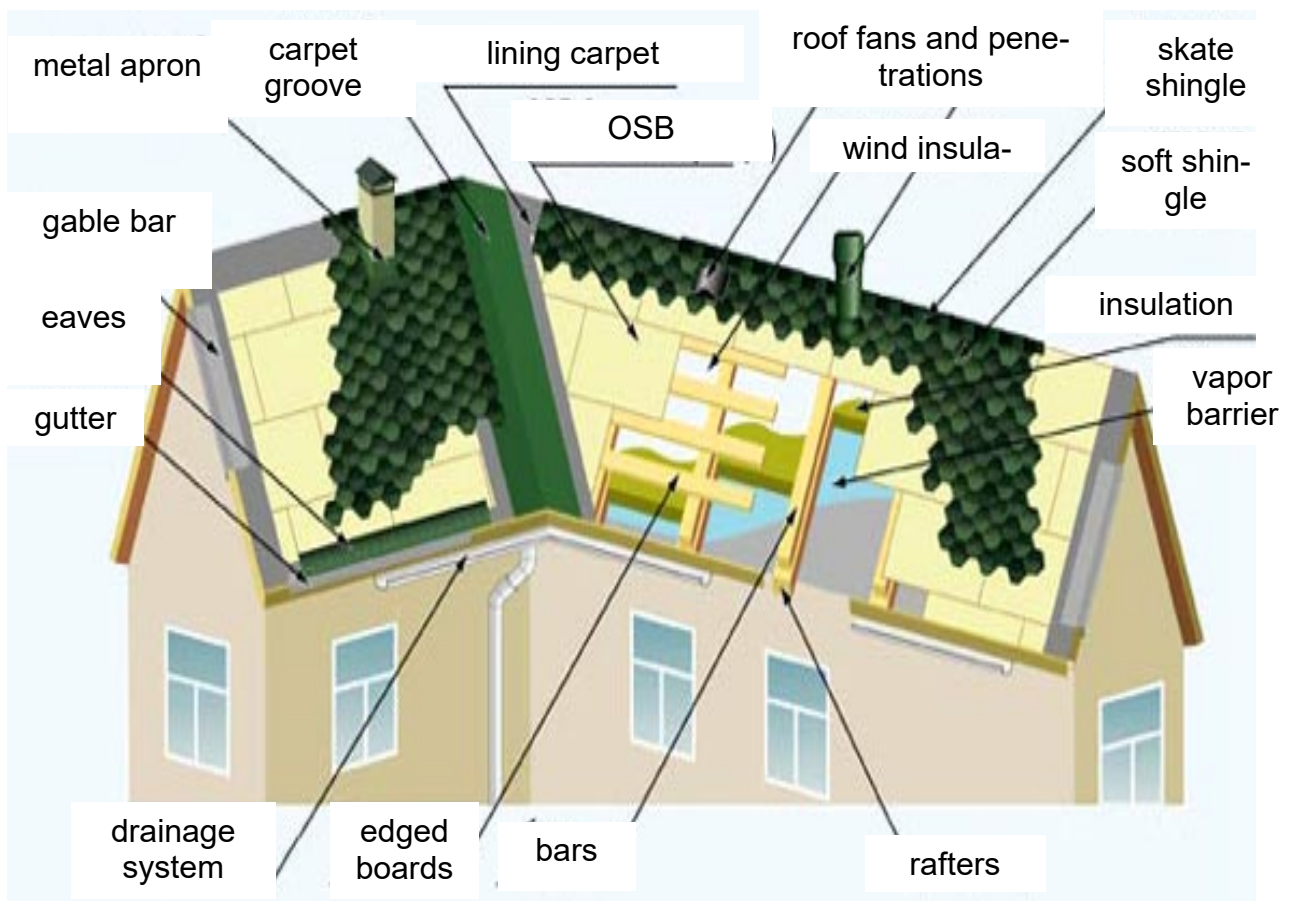

Figure 3.5 – Technological scheme of a roofing covering from a bituminous shingles

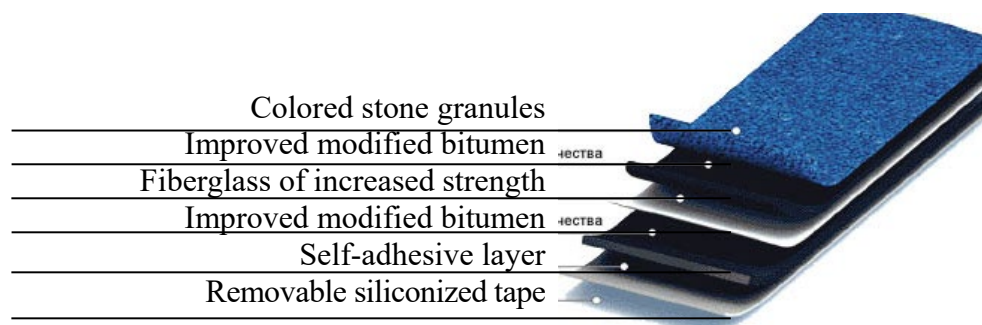

Figure 3.6 – Structure of KATEPAL bituminous shingles

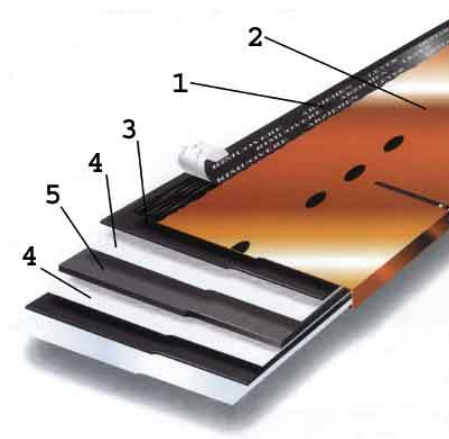

Figure 3.7 – The structure of the coating of soft shingles veneered with copper sheet (1 – adhesive strip; 2 – thin copper sheet; 3 – modified bitumen; 4 – fiberglass; 5 – intermediate bitumen layer)

Arrangement of the base under the roof. It is necessary to choose type of gutters fastening before installation of the basis under a roof:

- metal long brackets are mounted on mares and continuous patching;
- brackets made of polyvinyl chloride or metal, short brackets are pre-fixed to the windshield.

The basis under flexible shingles should be equal, continuous, rigid, dry. When making a base of solid wood flooring is recommended:

- to use narrow boards (up to 100 mm wide) and prevent them from pulling together;
- to sort the boards by thickness, the difference in height should not be more than 1-2 mm;
- to use fastenings with galvanized nails;
- to make joints of boards on length to place on support, in places of joints to hammer at least 4 nails.

A lattice + sheet material method is used when performing the base of the roof and to obtain high-quality surfaces:

- lattice is performed with a step multiple of the size of the sheet;
- cornices are the continuous basis ($L = 1000 \text{ mm}$);
- moisture-resistant plywood is fastened with galvanized nails with a step of 300 mm behind the lattice and with a step of 150 mm at the joints of the plates.

Laying of a lining carpet. The lining carpet or a rolled roofing waterproofing carpet is laid on a basis under a flexible shingles on all surface of a slope (Fig. 3.8).

Laying of rolled material is carried out in the direction from the lowered sites to the raised, parallel to eaves with an overlap in the cross direction of 150 mm and 100 mm – in the longitudinal. The base of the substrate is fastened with galvanized roofing nails with wide caps (not less than 8 mm) with a step of 200 mm. The overlap seams are sealed with glue. At roof slopes more than 18° (1:3) to 90° (1:0) it is allowed to lay a lining carpet only on perimeter of a roof in a zone of a skate, eaves, grooves, on end faces of a slope and in places of penetrations (Fig. 3.9).

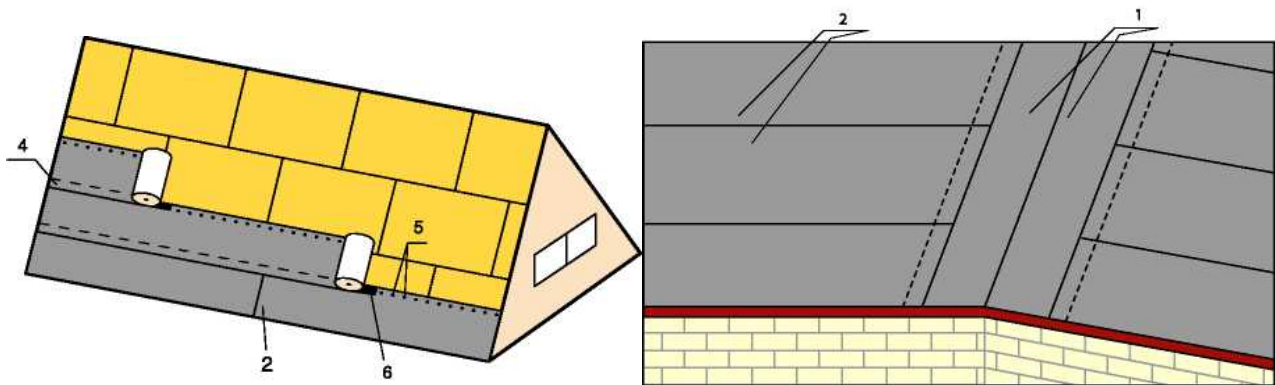

Figure 3.8 – Decomposition of a lining carpet on all surface of a roof: 1 – lining carpet in the groove; 2 – lining carpet; 4 – overlap of cloths 150 mm wide; 5 – nails with a step of 200 mm; 6 – gluing the overlap

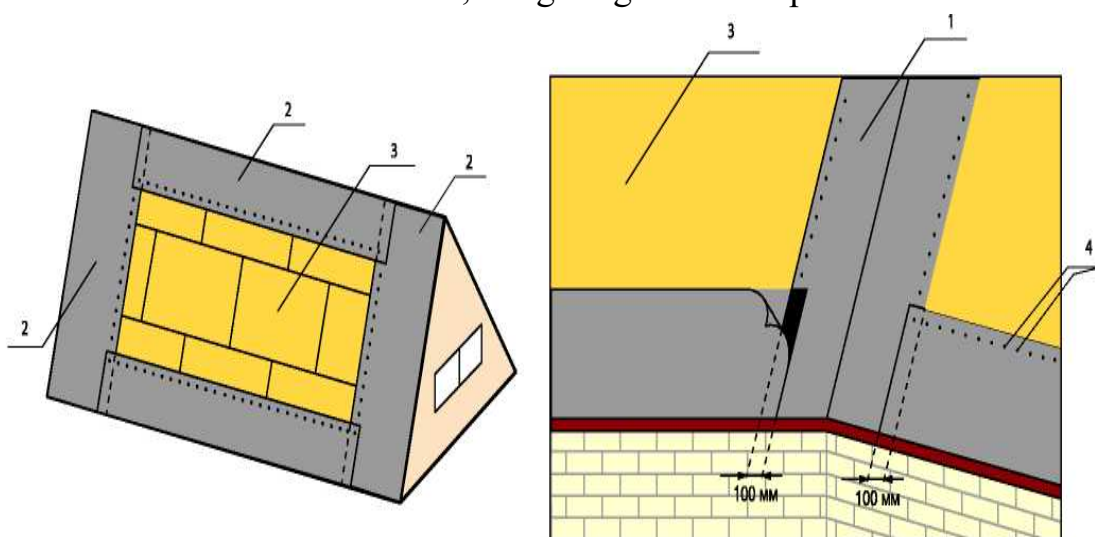

Figure 3.9 – Layout of the substrate layer around the perimeter: 1 – substrate layer in the groove; 2 – lining carpet; 3 – plywood; 4 – nails with a step of 200 mm

The metal eaves laths (droppers) are mounted on eaves of a roof over a substrate layer, and parts-gable slats are mounted with an overlap of 2 mm on face. They are nailed with roofing nails with a step of 100 mm, and in places of overlap – with a step of 30 mm (Fig. 3.10, 3.11). A layer of rolled material is laid in the grooves on top of the substrate layer to increase the water resistance of the roof that corresponds to the color of the roof shingles. The edges of the roll are fixed with galvanized nails, placed in steps of 100 mm (Fig. 3.12). The overlap of the carpet groove is sealed with glue with each other (transverse overlap) with a width of 150 mm. Self-adhesive cornice shingles are laid along the cornice overhang, having previously removed the protective film. The shingles are laid close to each other, departing from the edge of 10-20 mm. The cornice tile is nailed near the perforations, followed by overlapping of the fastening points with ordinary shingles (Fig. 3.13).

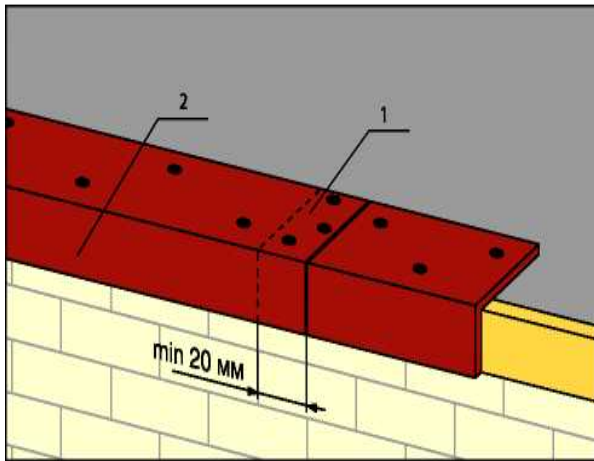

Figure 3.10 – The scheme of installation of a cornice lath: 1 – an overlap of laths 20 mm wide; 2 – cornice strip

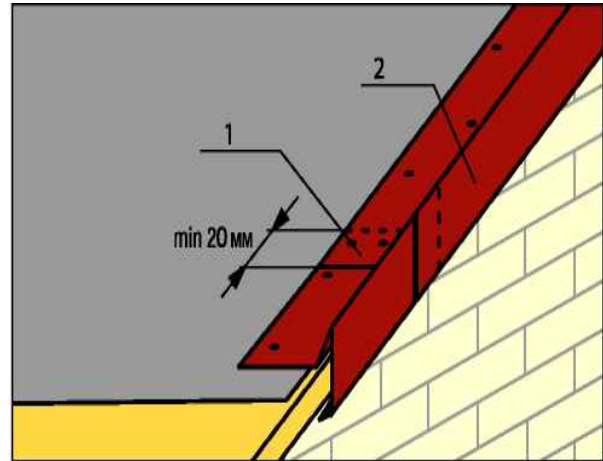

Figure 3.11 – The scheme of installation of a gable lath: 1 – an overlap of laths 20 mm wide; 2 – front bar

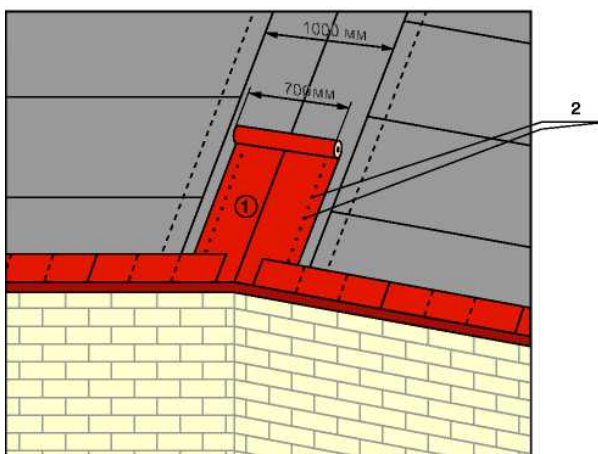

Figure 3.12 – Laying of rolled material in the groove: 1 – rolled carpet; 2 – nails with a step of 100 mm

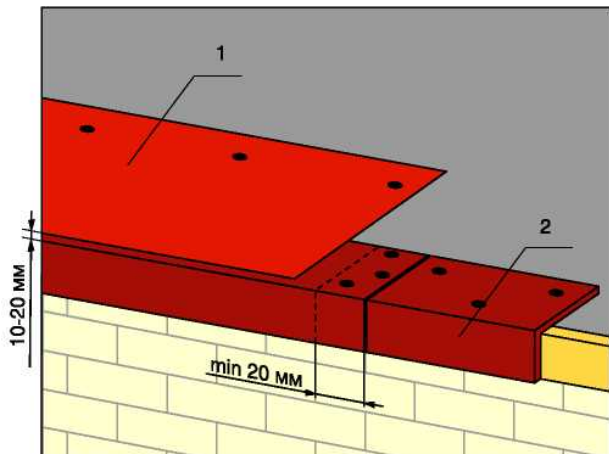

Figure 3.13 – Scheme of laying cornice shingles: 1 – self-adhesive cornice tile; 2 – cornice strip

Roofing shingles from 4-5 packages are used to avoid color deviations. Laying of cornice and ordinary shingles begins from the center of the cornice overhang in the direction of the end parts of the roof (Fig.3.14). The first row of shingles is laid so that its lower edge is located 10 mm above the lower edge of the cornice shingle (Fig. 3.15 a, 3.15 b), and the "petals" of the shingle cover the joints of the cornice shingles. Roof shingles are laid and nailed with four nails at a slope of a roof to 45 ° or six - at a bigger slope. Subsequent rows are laid so that the ends of the petals were flush or higher with the cutouts of the shingle of the previous row.



Figure 3.14 – Laying roof shingles

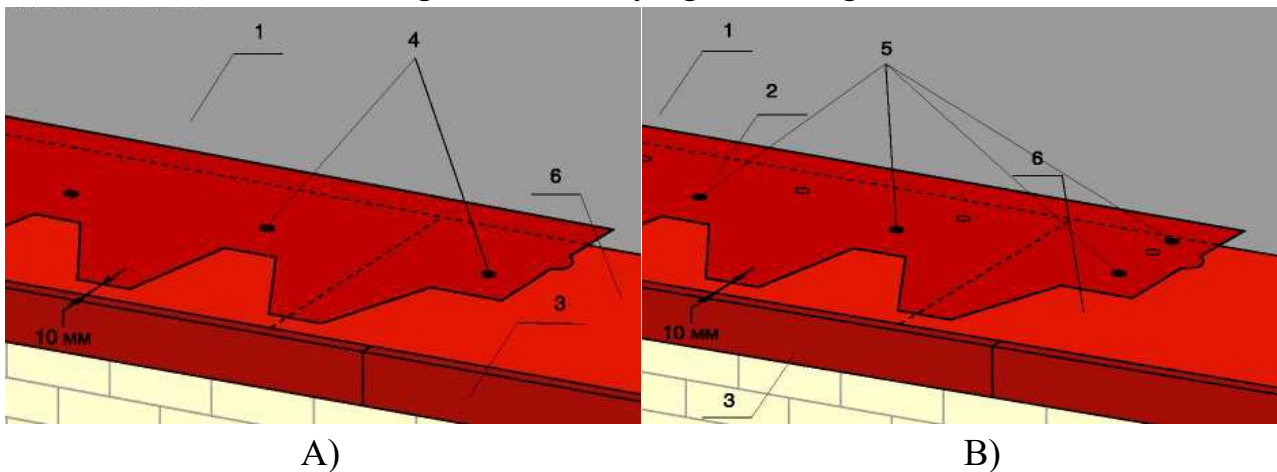

Figure 3.15 – Laying ordinary shingles: 1 – substrate layer; 2 – self-adhesive ordinary tile; 3 – cornice strip; 4 – six nails on shingles with a roof slope of more than 45°; 5 – four nails on shingles with a roof slope of less than 45°; 6 – self-adhesive cornice shingle

The end parts of the roof shingle are cut with a roofing knife along the edge, then glued with glue, which is applied with a spatula on a metal bar (Fig. 3.16).

In the groove the shingles are cut so that at the boundary of the intersection of the slopes an open strip 150-250 mm wide remains (Fig. 3.17). The edges of the shingles are glued along the cut line with a width of 100 mm glue. When cutting, plywood is placed under the shingle to damage the bottom layer.

The scheme of laying ordinary shingles is shown in Fig. 3.18.

Ridge is laid out from a shingle in the size of 250x333 mm which is received from a cornice shingle by its division on places of perforation into three parts. Having previously removed the protective film from the lower surface, the ridge shingles are laid on the ridge with a short side (250 mm) parallel to the ridge on the pre-laid layer

of ordinary shingles. The shingles are fastened with 4 nails (2 on each side of the ridge), placed so that they are under the overlap of 50 mm of the next shingle (Fig. 3.19). The last shingle must be glued with a sticker of 100 mm glue.

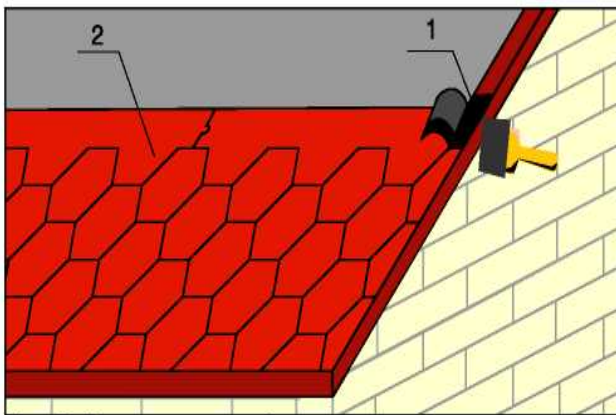

Figure 3.16 – Laying the end part of the roof: 1 – applying glue to the metal bar; 2 – ordinary shingle

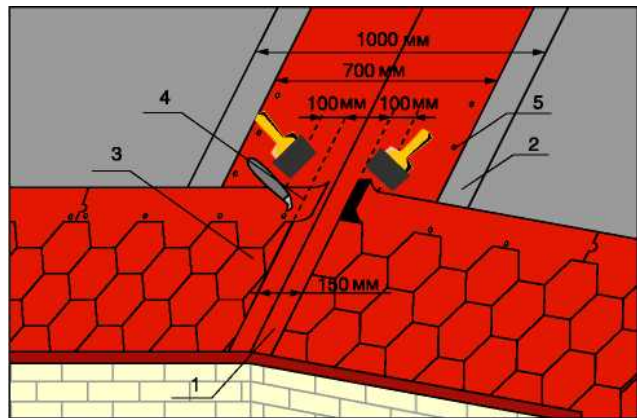

Figure 3.17 – Laying of a roofing shingle on a groove: 1 – rolled material in a groove; 2 – substrate layer; 3 – ordinary shingle; 4 – cut line; 5 – nails

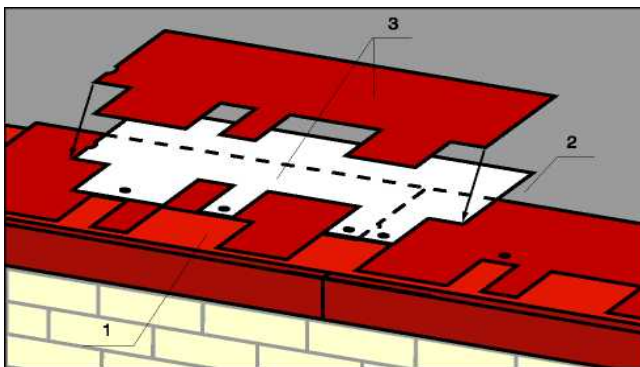

Figure 3.18 – Laying ordinary roof tiles: 1 – cornice shingle; 2 – substrate layer; 3 – shingles

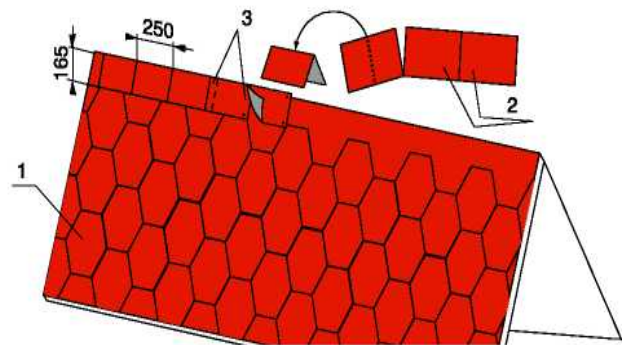

Figure 3.19 – Laying of a ridge shingle: 1 – ordinary shingle; 2 – ridge shingle; 3 – overlap of a ridge shingle 50 mm wide

The peculiarities of the roof on complex roofs are as follows. It is necessary to divide the complex surface into sectors of simple shapes (triangles, trapezoids, etc.). Each sector is equated to the plane where the installation is carried out. The combination of shingles from two sectors is carried out by mounting a ridge shingle or installation with an overlap of ordinary shingles of one sector on the shingles of another sector.

Plywood 4-8 mm thick is used for the base under the flexible shingle when installing roofs in the shape of a hemisphere, cone, ellipse, etc. which depending on the radius of curvature is sawn according to the performed scan into segments. The acute angle of each segment should converge at the top of. Laying of shingles starts with the

cornice of the rear (invisible) segment, and then the installation is carried out in different directions. The front segment is mounted last. To protect the end of the roof of the sharp tower, cone finishing element in the form of a metal spire, weather vane etc. can be used.

The groove should be arranged behind the pipe prior to the installation of the roofing around the chimney, on the slope of the roof from the ridge (Fig. 3.20), which directs the flow of water in both directions.

Plastered with a cement-sand solution adjacency of a roof to a wall or a brick chimney is carried out in the following order. A wooden rail of triangular cross-section 50x50 mm is sewn at the junction of the roof surface with the wall. The backing layer and the roof shingles are wound on the rail, and the joints are coated with glue. A strip of rolled material is glued along the wall. This strip is wound on the wall not less than 300 mm, and on the slope – not less than 200 mm. The upper part of the strip glued to the wall is protected by a metal strap, which is attached to the wall mechanically with sealing silicone sealant (Fig. 3.21).

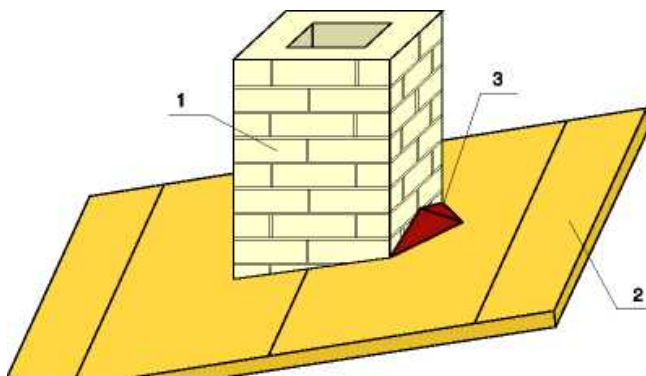

Figure 3.20 – Arrangement of groove: 1 – brick chimney; 2 – the basis under a roof from a continuous lattice; 3 – groove

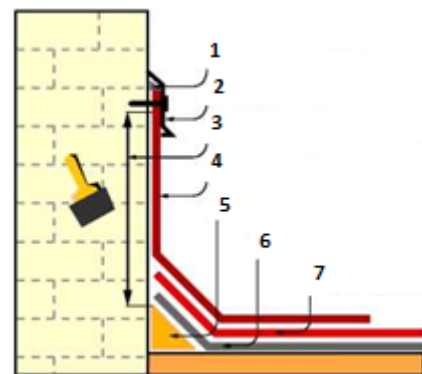

Figure 3.21 – Sealing of brick wall: 1 – silicone sealant; 2 – adjacency bar; 3 – sizing line; 4 – carpet groove; 5 – triangular rail; 6 – lining carpet; 7 – ordinary shingle

A protective cover with thermal insulation made of inflammable material must be provided on metal or asbestos-cement chimneys. Passages through the roof of ventilation pipes, antenna, etc. are arranged with cuffs made of EPDM rubber (ethylene-propylene rubber).

Installation of a flange for the fan is carried out in the following order. Hole is circled and a hole is cut in the base under the roof (Fig. 3.22, a). There is laid a carpet of a substrate in the size of 1x1 m with an overlap on an ordinary shingle and fixed with nails (Fig. 3.22, b). Glue is applied to the lower surface, then the base is installed and

fixed with nails with a step of 150 mm along the entire length of the central part (Fig. 3.22, c). The lower edge of the flange is placed in overlap on the already laid row of flexible shingles (Fig. 3.22, d). The surface of the flange is covered with glue and glued to ordinary shingles; the roof shingle is cut and adjusted close to the protruding flange body (Fig. 3.22, e). The necessary fan element is mounted on the installed flange, which is fastened with screws to the top of the flange. The verticality of the pipe is checked by the level (Fig. 3.22, f).

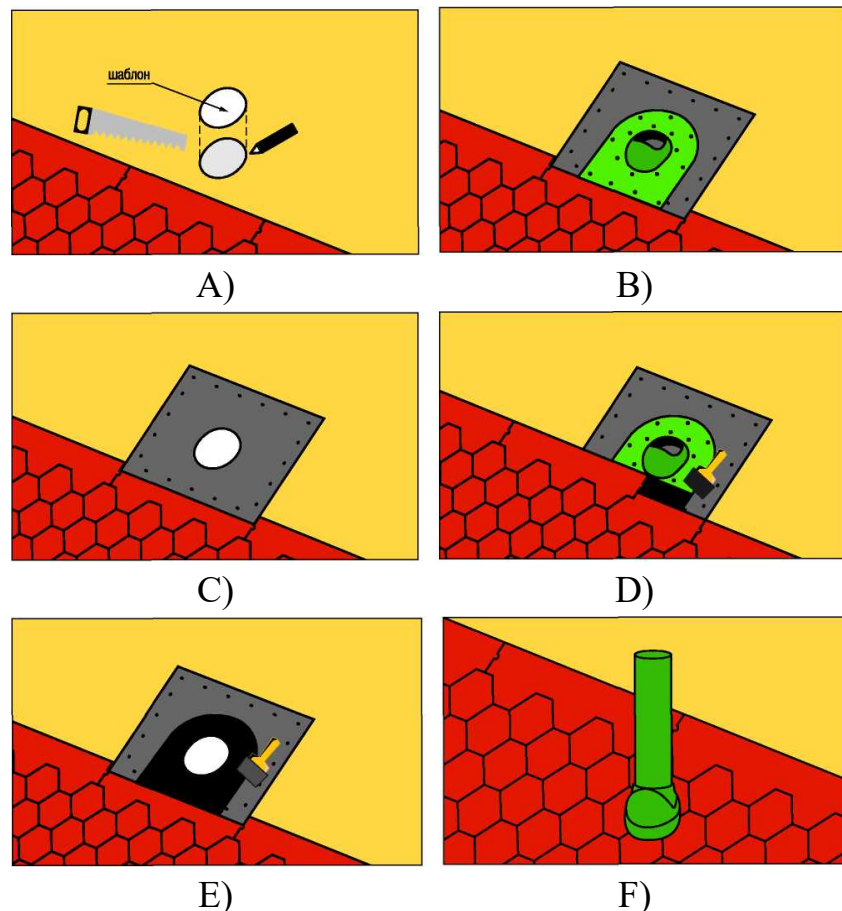

Figure 3.22 – Installation of the fan on a bituminous roofing

3.2.4 Structural and technological solutions for roof assemblies with bituminous shingles

When performing work on the installation of the roof, it is necessary to pay special attention to compliance with the technology of roof assemblies. Structural and technological solutions for these nodes are presented in Fig. 3.23-3.34. Symbols in the figures are as follows: 1 – roofing from a bituminous shingles; 2 – lining carpet; 3 – moisture-resistant plywood; 4 – lattice; 5 – bar 50x50 (to provide ventilation); 6 – windproof film; 7 – rafter leg; 8 – insulation; 8a – vapor barrier; 9 – bar 50x50 (for fastening of additional warming); 10 – vapor barrier; 11 – filing the ceiling; 12 – fan;

13 – ridge shingle; 14 – eaves frame; 15 – dropper; 16 – roof fan of sloping type; 17 – end carpet; 18 – dropper; 19 – structure of the building; 20 – sealant; 21 – SKT sealant; 22 – fastening collar; 23 – overlap; 24 – gutter; 25 – cornice filing; 26 – mauerlat; 26a – waterproofing layer under the mauerlat; 27 – cement-sand reinforced screed; 28 – auditory window; 29 – frame to create an air gap; 30 – plaster layer.

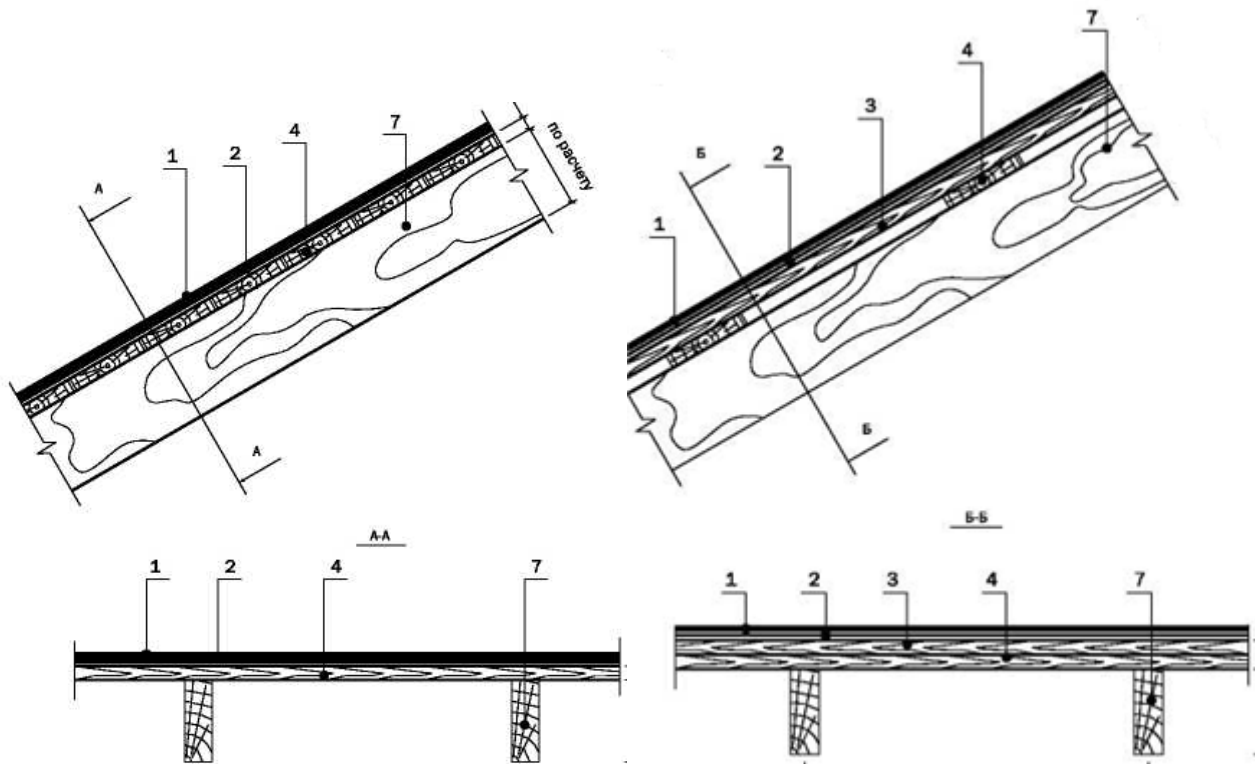

Figure 3.23 – The basis under a roofing covering from a bituminous shingles

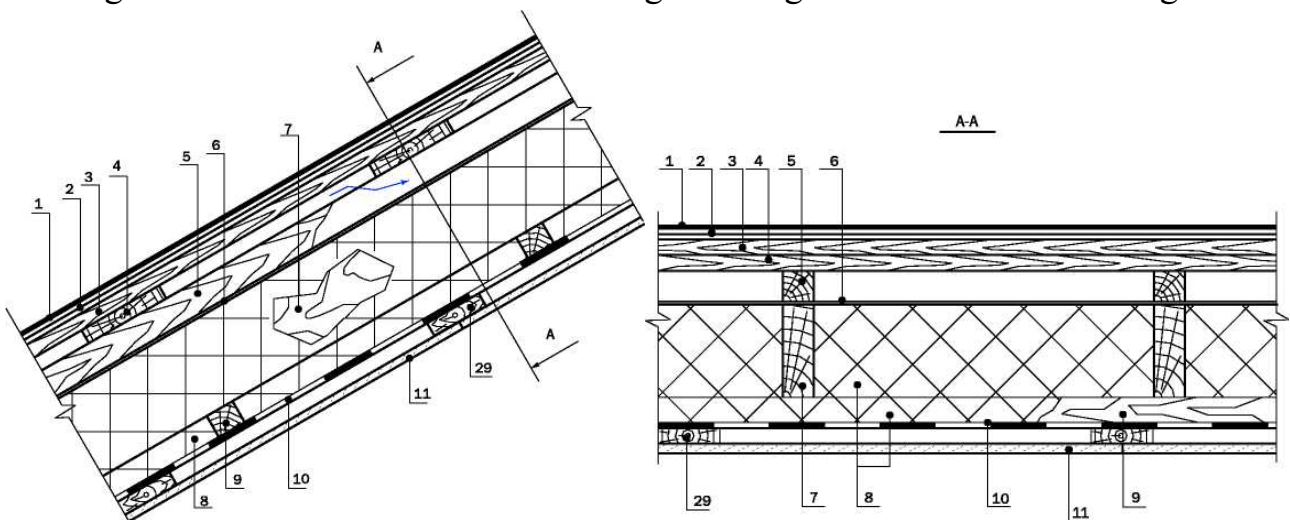

Figure 3.24 – Arrangement of the roofing pie of the attic floor, option with bilateral ventilation insulation

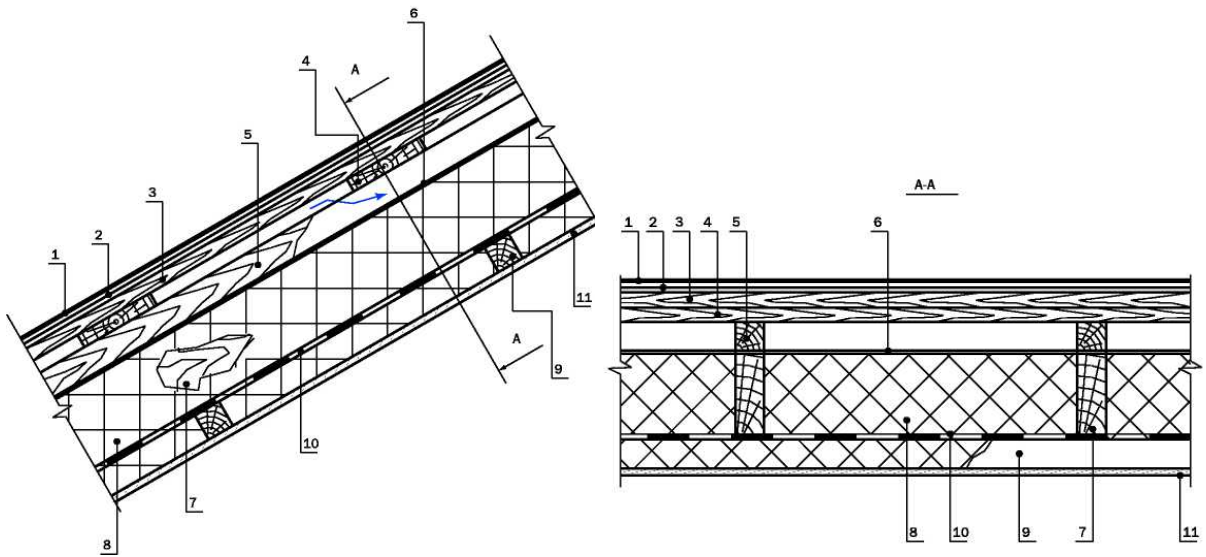

Figure 3.25 – Arrangement of the roofing pie of the attic floor, option with one-sided ventilation of the heater

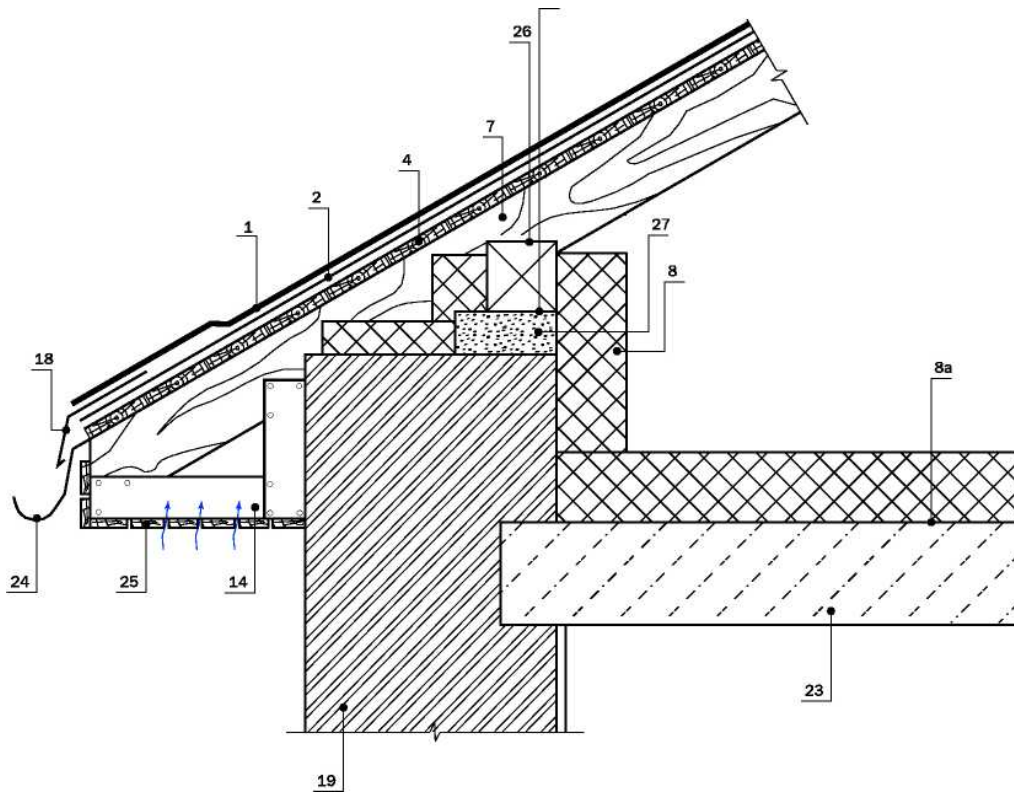

Figure 3.26 – Structural and technological solution of cornice overhang

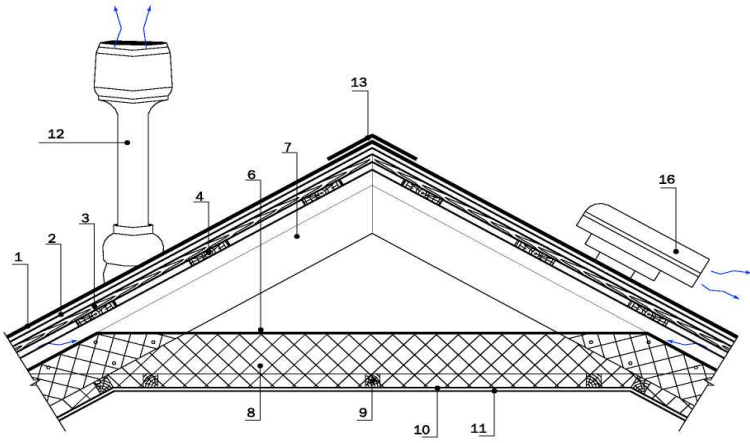

Figure 3.27 – Ridge attic roof unit with roof fans

Figure 3.28 – Ridge attic roof unit with aerator

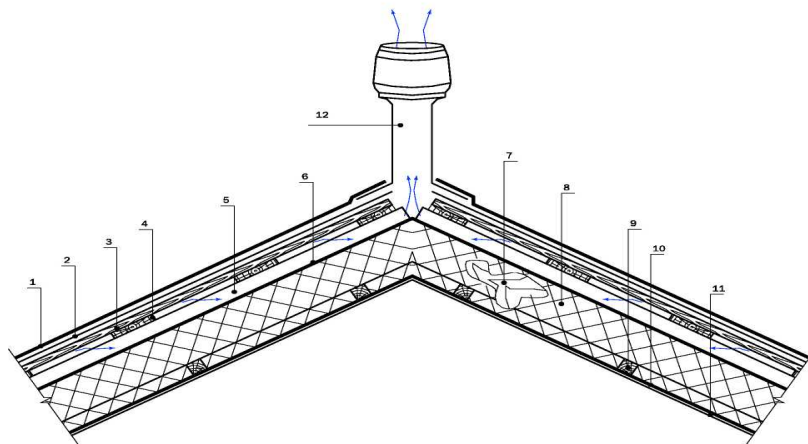
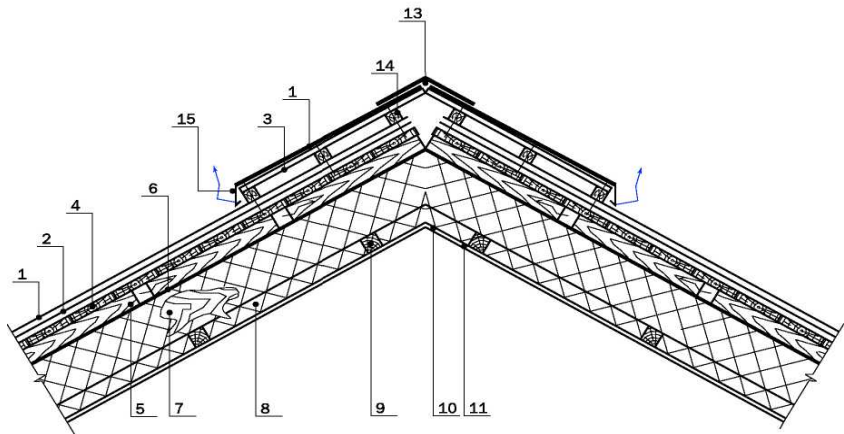
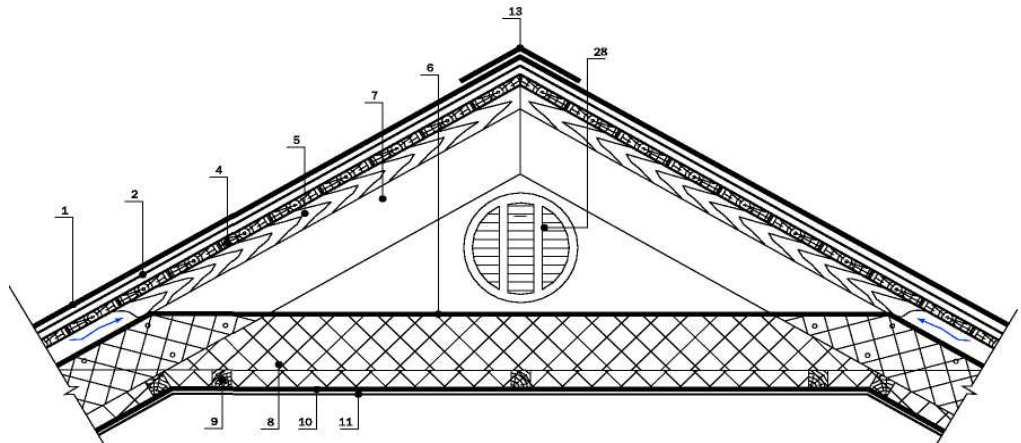

Figure 3.29 – Ridge attic roof unit with ridge deflector

Figure 3.30 – Ridge attic roof unit



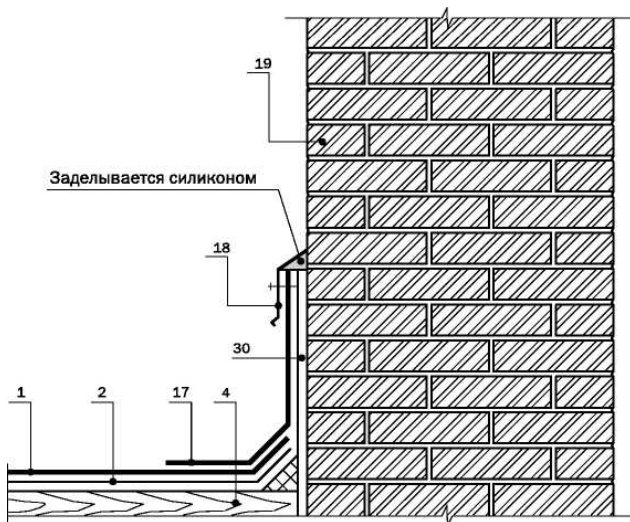

Figure 3.31 – Adjacency of the roof to the brick wall

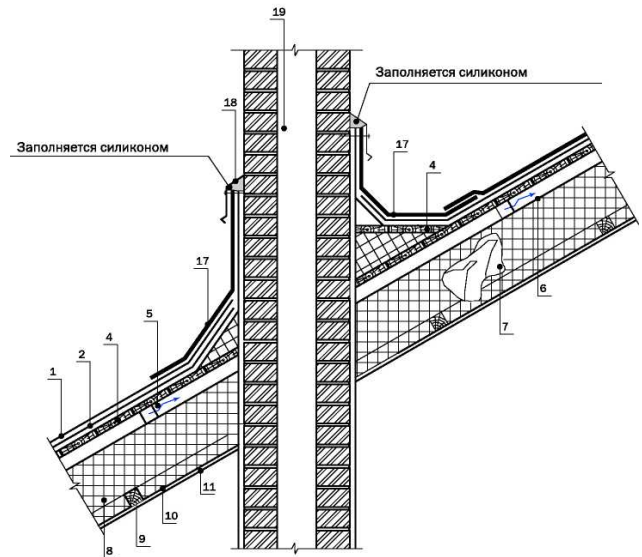

Figure 3.32 – Adjacency of the roof to the chimney

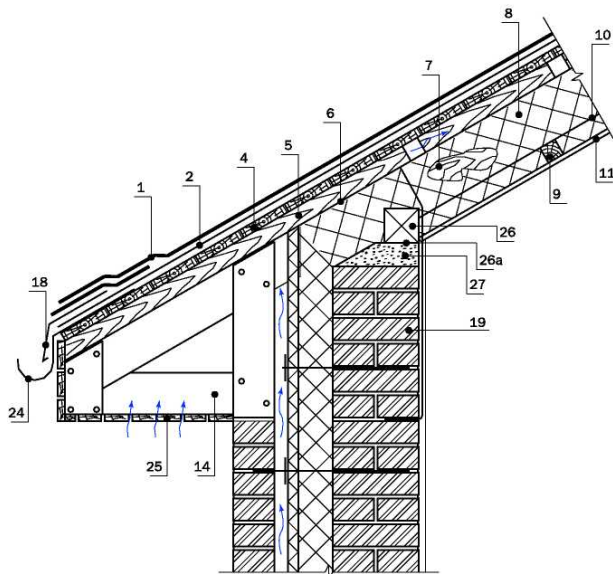

Figure 3.33 – Structural and technological solution of eaves overhangs of the attic floor

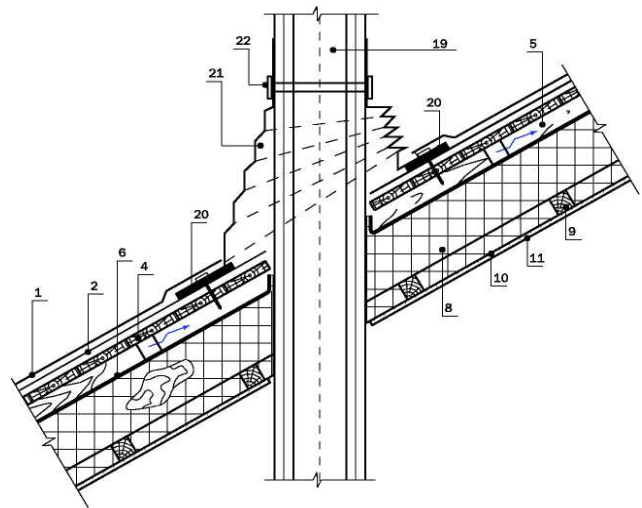

Figure 3.34 – Adjacency of the roof to the metal chimney

3.3 Calculation of labor costs and wages

Calculation of labor costs (table 3.1), which can be used when developing a work schedule or when issuing work orders to workers, is made in accordance with the requirements of State Building Code A.3.1-5-2016 "Organization of construction production" [3] and the Guide to State Building Code A.3.1-5-96 [4] on the development of construction organization project and works execution project.

Table 3.1 – The form of calculation of labor costs for the installation of bituminous shingles roofing

№	Rationale (rate code)	Name of works and costs	Unit	Number	Unit cost, UAH		Total cost, UAH			Labor costs of workers, man-hours.		
					Total	operation of ma- chines	Total	salary	operation of machines	not engaged in car maintenance		
					salary	including wages				including wages	those who service the machines	
							per unit	total				
1	2	3	4	5	6	7	8	9	10	11	12	
1	PH8-24-2	Arrangement of rafters and mauer- lats from logs	m ³							<u>23.5</u> 0.4692		
2	PH8-36-1	Arrangement of pasting vapor bar- rier in one layer	100 m ²							<u>29.7</u> 0.255		
3	PH8-37-3	Warming of coverings by plates from mineral wool or perlite on bi- tuminous mastic in one layer	100 m ²							<u>53.06</u> 1.1118		
4	PH8-36-1	Arrangement of pasting vapor bar- rier in one layer	100 m ²							<u>29.7</u> 0.255		
5	PH8-29-2	Arrangement of roofs from a flat tape tile	100 m ²							<u>198.05</u> 3.2232		
6	PH8-43-2	Filing of eaves under plaster at stone walls, ledge of eaves more than 500 mm	100 m							<u>172.62</u> 0.714		
		Total direct costs according to the estimate										

Column 1 indicates the number of the paragraph, table, column and position of the rate adopted in accordance with State Standard of Ukraine B D.2.4-8: 2012 "Resource element estimates for repair and construction work. Roofs (Collection 8)" [5]. State Standard lacks some types of work. In this case, the paragraphs "concerning" should be used by type of work, as similar as possible to needed work operations.

Column 2 indicates the code of the rate according to State Standard, which is the justification of labor costs and other indicators. Column 3 provides a list of work operations accepted in the technological map, provided by the collection of standards. In column 4 the units corresponding to norms are specified, in column 5 – the total volumes of work calculated earlier and transferred to units of measurement.

In accordance with the selected paragraph of State Standard in columns 6-7 indicates the price per unit of measurement (total, wages and operation of machinery (including wages)); in column 11 - labor costs of workers per unit of measurement (numerator - not engaged in maintenance of machines, denominator - those who maintain machines). Accordingly, in columns 8-10 and 12, the indicators for the entire volume of work are calculated. They are defined as the product of the volume of work (column 5) on the unit cost (columns 6-7) or time norms (column 11). At the end of the calculation, the results are given in columns 8-10 and 12.

When calculating the amount of work on the installation of the rafter system, it is advisable to use the form of table 3.2, by the net volume of wooden elements included in the rafter system. The amount of work on the installation and repair of roofs should be calculated by the total area of coverage without deducting the area involved in hearing windows, pipes, and without taking into account their treatment. The amount of work on hemming the cornices should be calculated around the perimeter of the building near the outer face of the wall.

Graphs 2-3 of table 3.2 are filled according to the developed plan of a roof. Column 6 is the secant of the roof angle (secant angle – the ratio of the hypotenuse to the adjacent (close) leg) – a coefficient calculated to convert the linear dimensions of the elements according to the plan in their actual size. The volume of a wooden element is calculated as the product of graphs 2, 3, 4, 5, 6 with the corresponding conversion into cubic meters (-9 degree).

For automated calculation of the calculation it is possible to use training versions of budget programs, among which the most common are AVK, MSmeta, "Budget Estimate Technology" and others. Here is an algorithm for preparing the calculation on the example of the software package AVK-5 (3.0.0) – Fig. 3.35-3.43, Appendix A (educational video):

1. *Creation of structure for construction, repair, mining works*: on the main screen of the program press the menu "Calculation documents"; in the list of construction objects, right-click; click "Create"; click "Create structure for construction, repair, mining works"; fill in "Name of the building", "Project code"; click "Save".
2. *Creation of object calculation*: in the list of object calculations, right-click; click "Create"; in the open window fill in "Chapter" (select "Chapter 2. Objects of the main purpose (individual project)", "Name of the object"; click "Save".
3. *Creation of local calculation*: in the list of local calculations, right-click; click "Create"; click "Create local calculation"; fill in the "Name"; click "Save".
4. *Creation of local calculation item (this step must be repeated after entering all the necessary budget items)*: in the local calculation, right-click; click "Create"; click "Create a local calculation item – a choice from the research institute"; in the open window to put marks in front of the collection "(PH) Repair and construction works DSTU B D.2.4-2021"; click "Start search"; it is possible to search in the open window in several ways – if you have a rate code, you can enter it in the field "PO/PO Part", if you have keywords, you can enter them in the field "Text", and you can search in the hierarchical structure of the collection; press the "Find All" key; click on the desired position; enter the scope of work in the field "Quantity".

Table 3.2 – Form of calculation of the work amount on installation of the rafter system

Item name	Number of elements	Length according to the plan, mm	Width, mm	Height, mm	Secant angle of inclination	Volume of wooden element, m ³
1	2	3	4	5	6	7
Rafters			200	100		
			200	100		

Mares			200	25		
			200	25		

Ridge			200	200	1	
Filing			200	25	1	
Windshield			200	25	1	
Mauerlat			200	100	1	
Stand			100	100	1	
Angle brace			100	100	1	
Pull			100	100	1	
Total volume of wood of rafter elements, m ³						

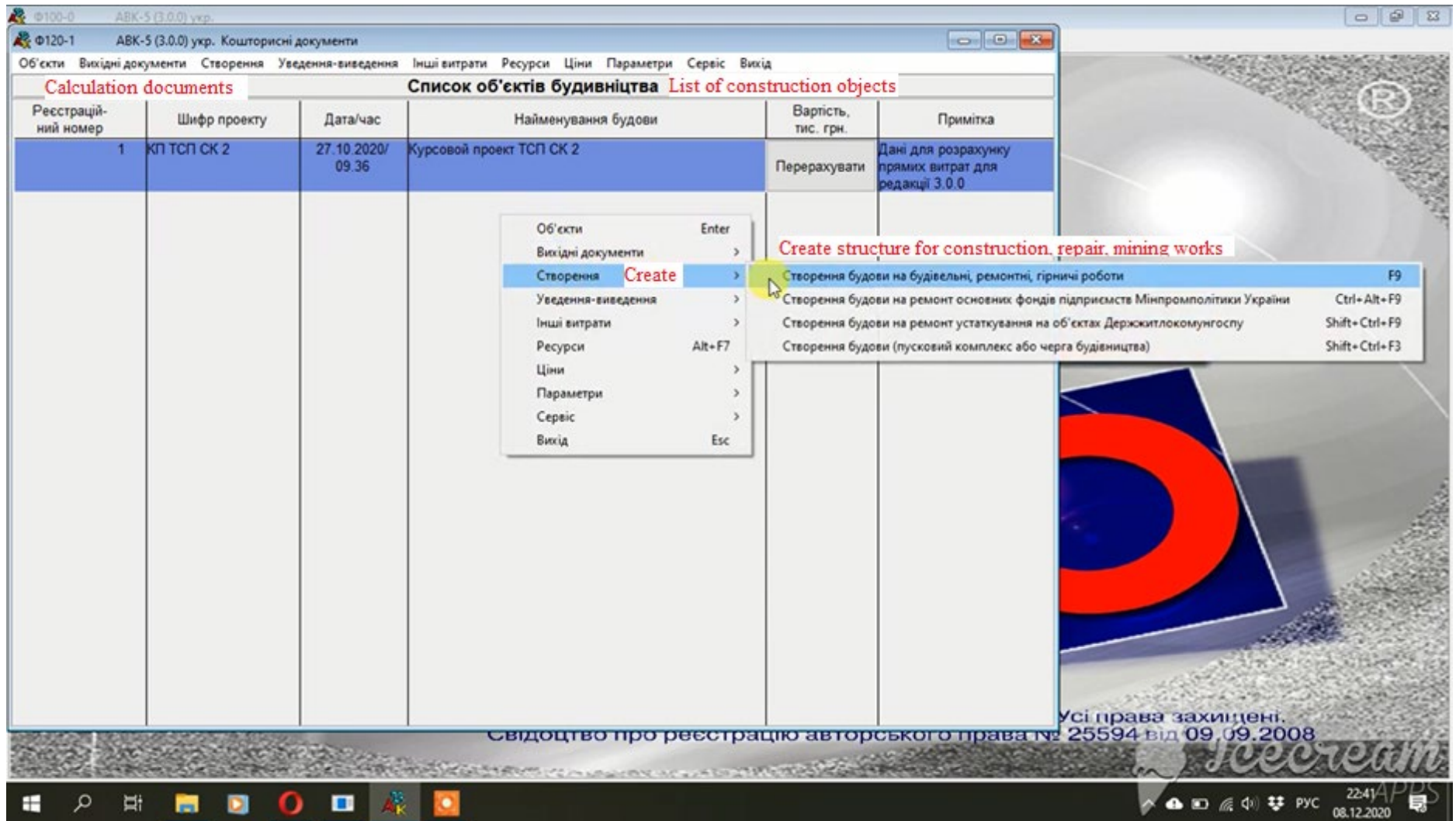

Figure 3.35 – Step 1 "Creation of structure for construction, repair, mining works": creation of structure for construction, repair, mining works

Ф100-0 АВК-5 (3.0.0) ukr.
Ф153-1 АВК-5 (3.0.0) укр. Кошторисні документи

Створення будови Creation of structure for construction, repair, mining works

(на будівельні, ремонтні, гірничі роботи)

Загальні дані Показники витрат Показники адм. витрат і прибутку Додаткові дані

Реєстраційний номер будови Максимальний номер будови

Найменування будови Name of the building

Тип місцевості, який визначає за умовчанням відстань перевезення будівельних вантажів

Відстань перевезення будівельних вантажів

Примітка в Списку будов

Шифр проекту Project code

Найменування організації, що затверджує

Найменування підприємства

Склав: І. Б. Прізвище Посада

Перевіряв: І. Б. Прізвище Посада

Вибір або створення папки для зберігання файлів

Оновити Оформлення Вихідних Даних

Save

Усі права захищені.
Свідоцтво про реєстрацію авторського права № 25594 від 09.09.2008
Icecream

22:42 APDS
08.12.2020

Figure 3.36 – Step 1 "Creation of structure for construction, repair, mining works": filling in the fields "Name of the building", "Project code"

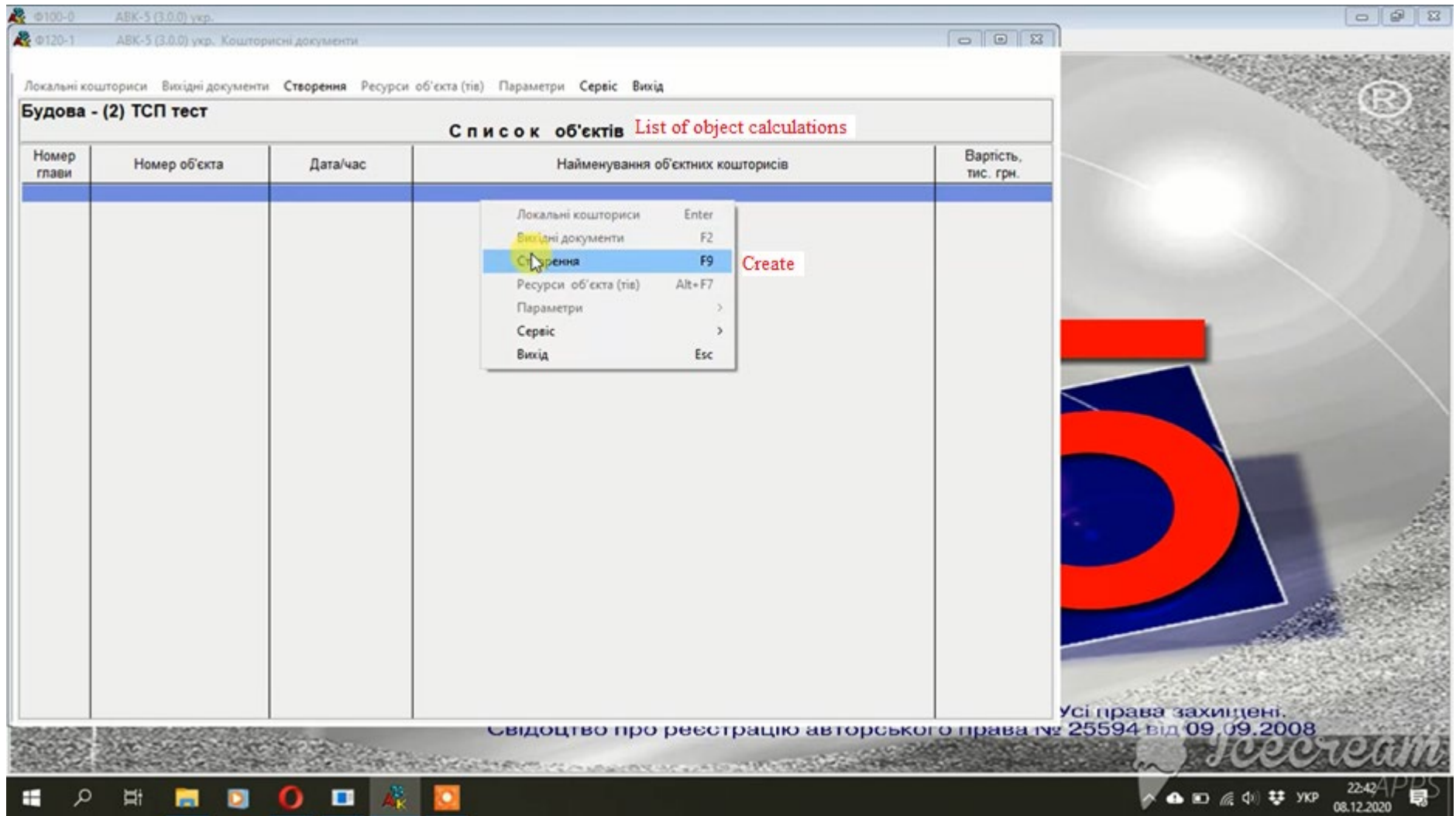

Figure 3.37 – Step 2 "Creation of object calculation"

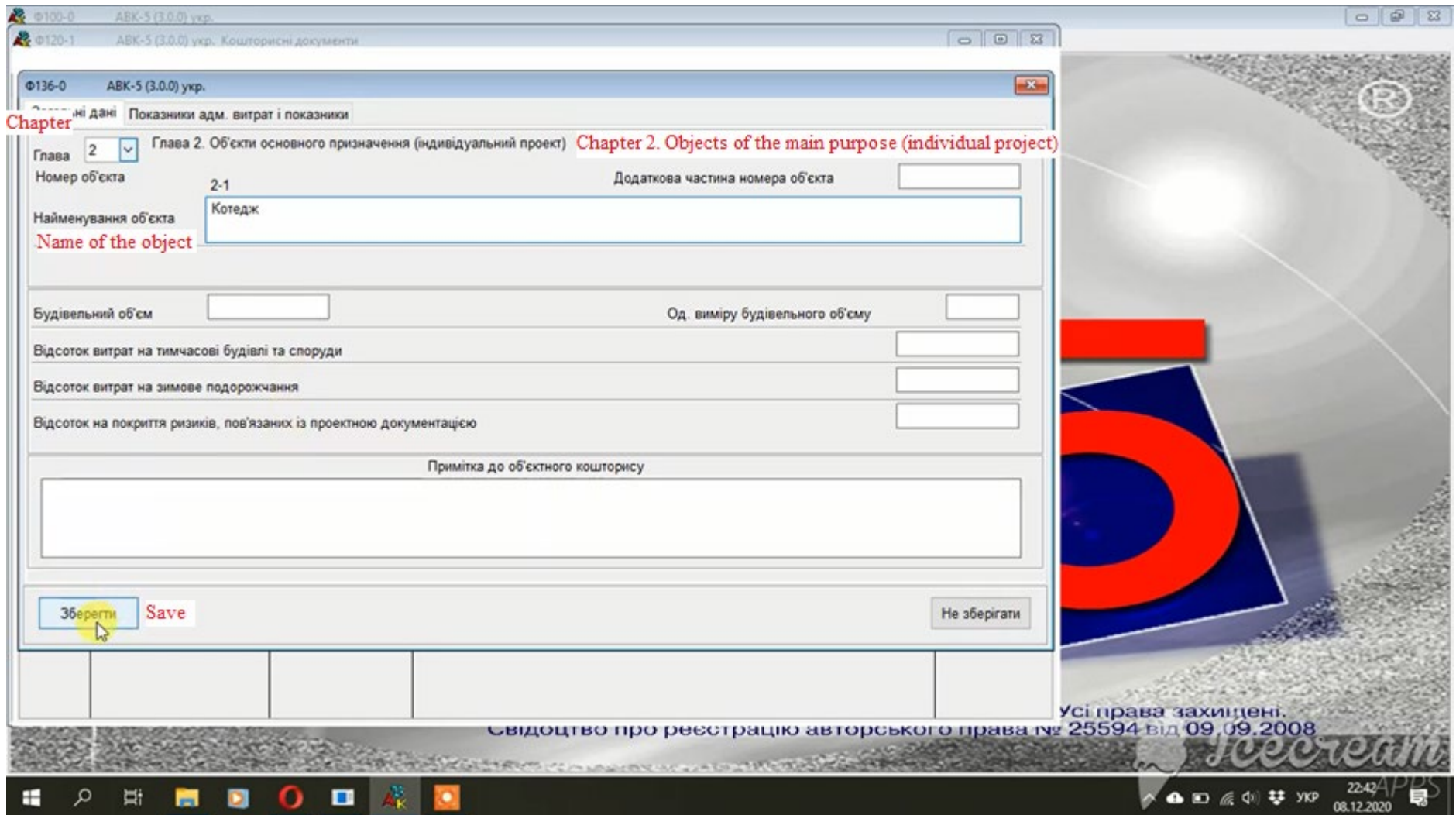

Figure 3.38 – Step 2 "Creation of object calculation": filling in "Chapter", "Name of the object"

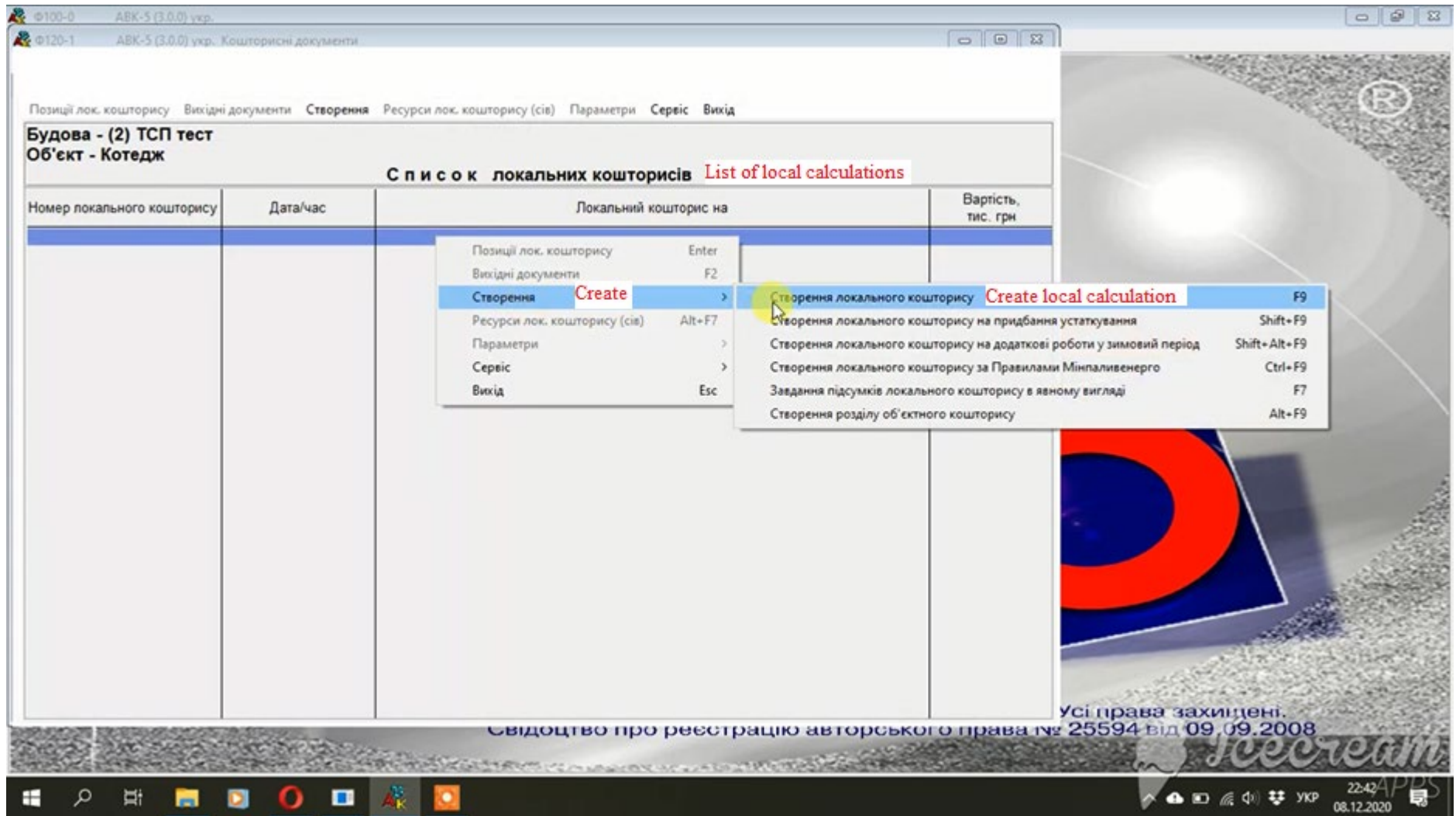

Figure 3.39 – Step 3 "Creation of local calculation"

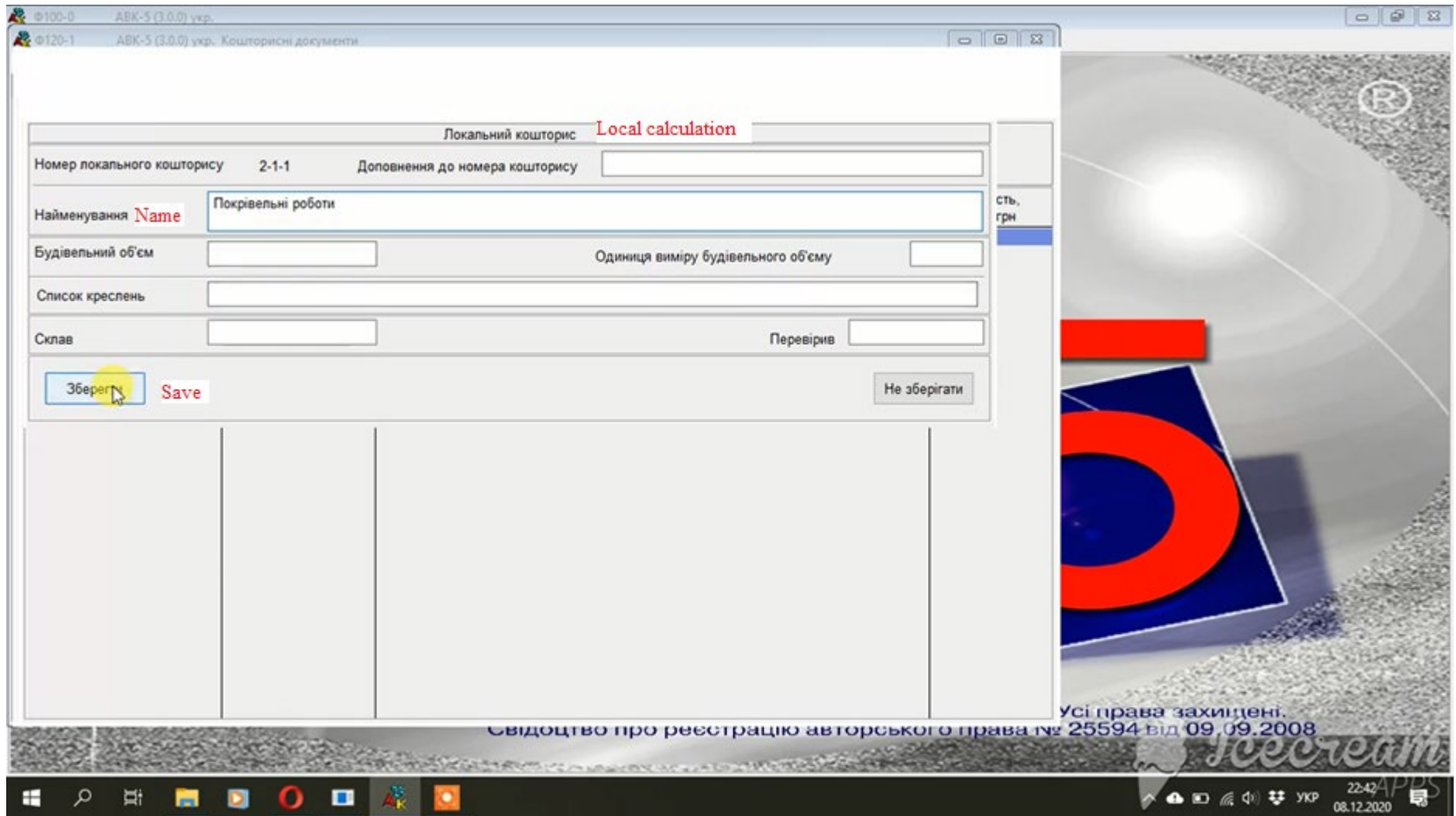

Figure 3.40 – Step 3 "Creation of local calculation": fill in the "Name"

Ф127-1 АВК-5 (3.0.0) укр. Кошторисні документи

Створення Ресурси позицій, що виділені Параметри Вихідні документи Підсумок зведеного кошторисного розрахунку Повний екран Сервіс Вихід

Будова - (2) ТСП тест
Об'єкт - Котедж
Локальний кошторис на Покрівельні роботи Local calculation

№ п/п	Шифр і номер позиції нормативу	Найменування робіт і витрат, одиниця виміру	Кількість	Вартість одиниці, грн.		Загальна вартість, грн.			Загально-новиробничі витрати, грн.
				усього	експлуатації машин у т.ч. заробітної пп.	усього	заробітної плати	експлуатації машин у т.ч. заробітної	
Create a local calculation item – a choice from the research institute									
				<ul style="list-style-type: none"> Створення Create > Створення позиції локального кошторису - вибір з НДі Alt+F2 Ресурси позицій, що виділені Alt+F7 Параметри > Вихідні документи Ctrl+Alt+F2 Підсумок зведеного кошторисного розрахунку Shift+I Повний екран Shift+E Сервіс > Вихід Esc Створення позиції локального кошторису - завдання ПО явно Ctrl+F3 Створення текстової позиції Shift+F3 Створення позицій уведенням КП Shift+F2 Створення рядка числових параметрів (значень і ознака друку) F2 Створення заголовка - Підземна частина Alt+F6 Створення заголовка - Надземна частина Ctrl+Alt+F7 Створення заголовка - Відділ Ctrl+F5 Створення заголовка - Розділ F4 Створення рядка - Примітка F3 Вставити групу рядків з текстового файлу Alt+F3 Створення нової Комплексної Позиції в Списку КП Ctrl+Alt+F3 					

Витрати ресурсів:

матеріалів, грн. на одиницю усього

витрати труда робітників, не зайнятих обслуговуванням машин, люд.-г.

витрати труда робітників, що обслуговують машини, люд.-год.

Разом по кошторису

22:42 APPS 08.12.2020

Figure 3.41 – Step 4 "Creation of local calculation item": Creation of local calculation item – a choice from the research institute"

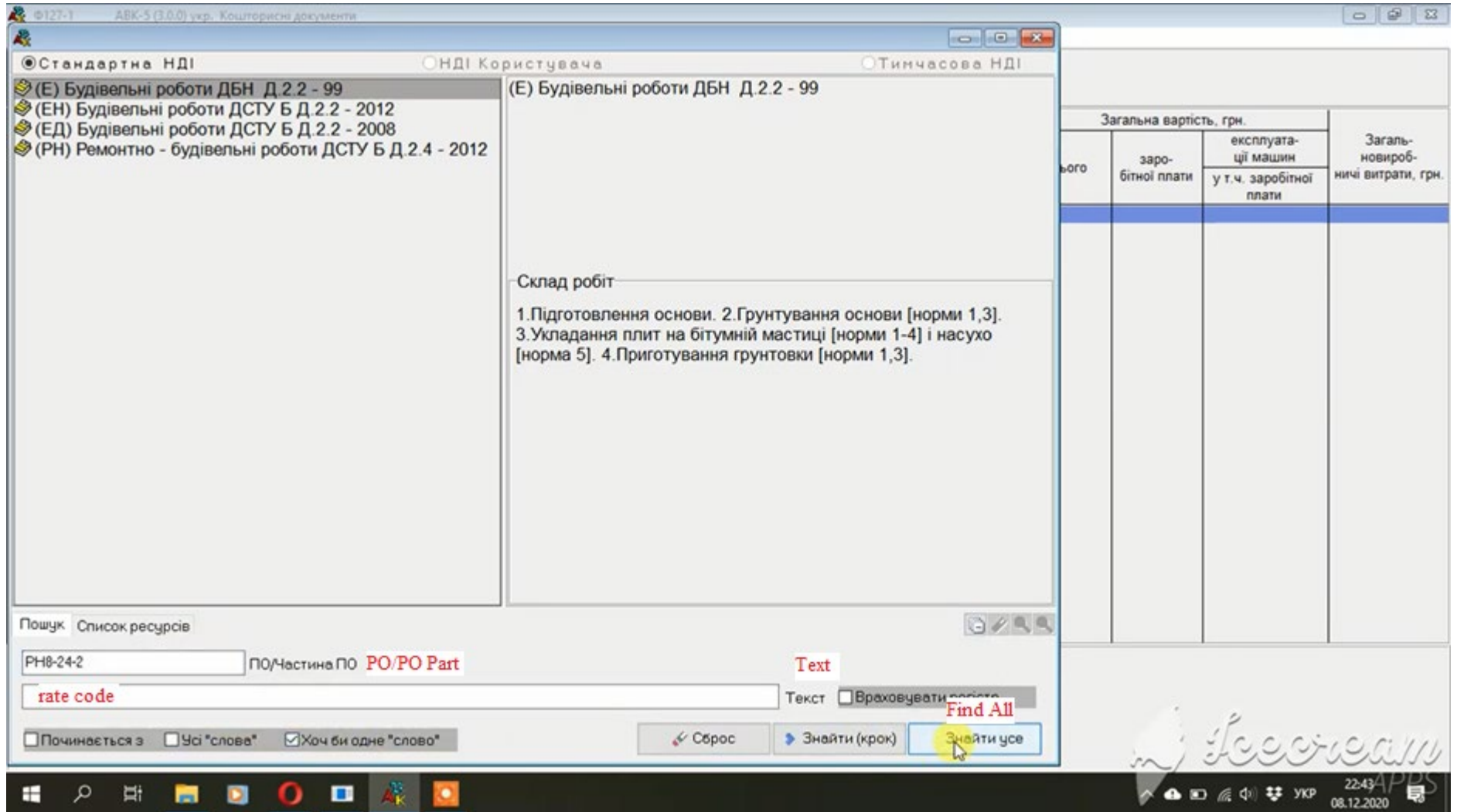

Figure 3.42 – Step 4 "Creation of local calculation item": search for the item code

Ф127-1 АВК-5 (3.0.0) укр. Кошторисні документи

Створення Ресурси позицій, що виділені Параметри Вихідні документи Підсумок зведеного кошторисного розрахунку Повний екран Сервіс Вихід

Будова - (2) ТСП тест
Об'єкт - Котедж
Локальний кошторис на Покрівельні роботи local calculation

№ п/п	Шифр і номер позиції нормативу	Найменування робіт і витрат, одиниця виміру	Кількість Quantity	Вартість одиниці, грн.		Загальна вартість, грн.			Загально-виробничі витрати, грн.
				усього	експлуатації машин	усього	заробітної плати	експлуатації машин у т.ч. заробітної плати	
				заробітної плати	у т.ч. заробітної плати				
1	PH8-24-2 rate code	Улаштування кроків і мауерпатів з колод м3	23,9			434927	103793	1960 1745	87080

Витрати ресурсів:

	на одиницю	усього	Разом по кошторису			
матеріалів, грн.	1377,30	329174	434927	103793	1960	89345
витрати труда робітників, не зайнятих обслуговуванням машин, люд.-г.	23,5	5616,5				
витрати труда робітників, що обслуговують машини, люд.-год.	0,4692	112,14			1745	

22:43 APBS 08.12.2020

Figure 3.43 – Step 4 "Creation of local calculation item": enter the scope of work in the field "Quantity"

3.4 Calendar schedule of works

The calendar schedule of works is made according to the form given in table 3.3, according to the following indicators.

Table 3.3 – Form of work schedule

Name of works	Labor costs, man-hours	Duration, days	The number of workers per shift	Years, quarters, months, days
1	2	3	4	5-....

Column 1 "Name of works" lists main, auxiliary and related work processes and operations that are part of the complex process displayed the technological map in the technological sequence. In column 2 – the corresponding values of labor costs of workers for processes and operations equal to the sum of the numerator and denominator of column 12 of the calculation form table 3.1. Columns 1, 2 are taken from the calculation.

Column 3 calculates the number of days required to perform the relevant work. It is calculated as a fraction of the division of labor costs by the total volume of work (column 2) by number of workers in shifts (column 4) and division by the number of working hours per day (usually taken equal to 8 hours). It is often necessary to plan work taking into account the directive period of work. In this case, you need to calculate the number of workers, based on the overall labor costs and the directive period. To do this, divide the total labor costs of all processes and operations on the directive period of work and the number of working hours per day. The resulting number must be rounded up to the nearest whole number – this will be the required number of workers to perform work in the directive period.

After that the schedule of works is made. Thus in each row lines are made, according to duration of works, quantity of working shifts. The work schedule indicates the sequence of work processes and operations, their duration and interconnection on the site of work and time. The duration of the complex construction process, on which the technological map is drawn up, must be a multiple of the duration of the work shift in one-shift work or the working day in two-and three-shift work.

Besides labor spent of time the average brigade of works is specified in State Standard of Ukraine. In this case, you can determine the composition of the workers. So, for example, if the average category is 3.6, then the team may consist of 1 working 5th category, 1 – 4th and 1 working 2nd category $[(5+4+2)/3 = 3.6]$.

If the work is performed using mechanisms, you can schedule them in 2 or 3 shifts, or increase the number of mechanisms. The latter can be done only if the conditions of the construction site allow it, based on ensuring compliance with the rules of production safety and labor protection.

If the work is performed manually or with mechanized tool and it is necessary to accelerate it, then the number of workers should be increased, which is indicated in column 4. This increase should be a multiple of the accepted brigade composition.

When drawing up a calendar schedule, it is necessary to take into account the breakdown of the entire volume of work into grips, technological sites, etc., as well as the requirements of regulatory documents on the organization of flow methods of work.

43 If the duration of work on one grip or site is much less than one day, it is necessary to perform an hourly schedule for a typical grip. Then the amount of time to perform all work on the building as a whole should be calculated and the sequence of work on the grips should be indicated in the note or second schedule of work should be made taking into account all the workload and the sequence of their performance on the grips.

Modern PC project management software can be used to create a calendar schedule. These are SureTrak Project Manager and Microsoft Project. The American company Primavera Systems, Inc. has developed a number of similar programs. These are Primavera Project Planner Professional (P4), Time Line 6.5, Open Plan Professional and more.

These programs not only allow you to make and quickly adjust the line schedule in the process. In this case, it can be shown in the same way as on the network model: time reserves, the relationship between the works, the "critical path". The same programs allow making, if necessary, schedules for financing works, submission of materials, mechanisms, etc. And most importantly – they allow conducting operational planning and instantly make any adjustments to the work process.

Visual linear form of the graph and the presence of indicators characteristic of the network model (time reserves, "critical" path, etc.), combined with the ability to quickly adjust, make such graphs indispensable and very useful in the implementation of construction projects.

Here is an algorithm for preparing a schedule of work on the example of the software package Microsoft Project 2016 – Fig. 3.44-3.49, Appendix A (educational video):

1. *Entering data into the tabular part of the Microsoft Project interface:* right-click on the title; select the column "Labor costs"; insert the name of the task and labor costs of the calculation; select "Automatic" task scheduling mode in the appropriate column for all created tasks; hide the Indicators, Task Mode, and Predecessors columns when not needed.

2. *Creating a labor resource for modeling employees:* switch to the "Resource Sheet" display in the lower right corner of the program; create a labor resource "Roofer" by entering its name in the column "Name of the resource"; appoint of a known larger maximum amount of resource in the column "Max. units".
3. *Assignment of the required number of workers to the task to calculate the duration:* calculate the required number of workers, based on the overall labor costs and the directive period of work; open the first task in the graph by double-clicking with the left mouse button; in the open window "Task Information" select the tab "Resources"; assign the Roofer resource from the drop-down list; indicate the required number of workers in the field "Units" in percent, where 100% means the full load of one worker, 1000% – ten, etc .; click "OK"; capture the allocation of resources on the first task and "stretch" on all remaining tasks.
4. *Defining of technological connection of works:* capture the first task in the graph in the right graphical part of the interface and drag to the next task in the technological sequence; repeat for each subsequent task. Assigning work linkages is also possible by other methods – by selecting predecessors on the "Predecessors" tab of the "Task Information" window; by entering the number of the previous task in the corresponding field of the column "Predecessors" of the tabular part of the interface.

The screenshot displays the Microsoft Project Professional interface in the 'Task Indicators' mode. The ribbon at the top shows the 'Task' tab selected, with various options for task management. The main workspace is divided into a Gantt chart area on the left and a tabular task list on the right. The task list table has the following structure:

Режим задачи	Название задачи	Начало	Окончание	При	30 Ноя '20	07 Дек '20	14 Дек '20	21 Дек '20	28 Дек '20
	Трудозатраты								

A yellow circle with a crosshair is positioned over the 'Labor costs' column header in the task list table. The status bar at the bottom indicates 'Изменить' and 'Новые задачи: Планирование вручную'.

Figure 3.44 – Step 1 "Entering data into the tabular part of the Microsoft Project interface": add a column "Labor costs"

The screenshot shows the Microsoft Project Professional interface. The top ribbon includes 'Инструменты диаграммы Ганта' and 'Проект1 - Project профессиональный'. The main area displays a Gantt chart and a task table. A context menu is open over the task table, with the 'Hide the columns' option highlighted. The task table contains the following data:

№	Имя задачи	Трудозатра	Длительность	Начал
1		0 ч	1 день?	Вт 08.1
2	окв і мауерпатів з копод	561.65 ч	1 день	Вт 08.1
3	клеювальної пароізоляції в один шар	70.98 ч	1 день	Вт 08.1
4	ттів плитами з мінеральної вати або перліту на бігумній мастиці на кожний наступний шар	117.83 ч	1 день	Вт 08.1
5	клеювальної пароізоляції в один шар	70.98 ч	1 день	Вт 08.1
6	...трічкової черепиці	473.34 ч	1 день	Вт 08.1
7	низів під штукатурку при кам'яних стіпах, виступ карнизу більше 500 мм	93.21 ч	1 день	Вт 08.1

Figure 3.45 – Step 1 «Entering data into the tabular part of the Microsoft Project interface»: hide the columns "Indicators", "Task mode" and "Predecessors"

The screenshot displays the Microsoft Project interface. At the top, a Gantt chart shows a task starting at 08:12:20 and ending at 08:12:20. Below the Gantt chart is the Resource Sheet table.

Name of the resource	Units	Standard rate	Overtime rate	Cost per hour	Allocation	Calendar	Code
1. Покрівельник	Трудовой	0,00 в/ч	0,00 в/ч	0,00 в	Пропорционал	Стандартный	
Roofer	labor						

Handwritten annotations in red text are present: 'Max.' above the 'units' column header, 'Gant diagram' pointing to the Gantt chart, and 'Resource Sheet' pointing to the table.

Figure 3.46 – Step 2 "Creating a labor resource for modeling employees"

The screenshot shows the Microsoft Project interface. The task list is as follows:

Название задачи	Трудозатр	Длительность	Начало
1 Захватка 1	1387,99 ч		Вт 08.12.20
2 Улаштування кров і мауерлатів з колод	561,65 ч		Вт 08.12.20
3 Улаштування обклеювальної пароізоляції в один шар	70,98 ч		Вт 08.12.20
4 Утеплення покриттів плитами з мінеральної вати або перліту на бітумній мастиці на кожний наступний шар	117,83 ч	1 день	Вт 08.12.20
5 Улаштування обклеювальної пароізоляції в один шар	70,98 ч	1 день	Вт 08.12.20
6 Улаштування покрівель із плоскої стрічкової черепиці	473,34 ч	1 день	Вт 08.12.20
7 Підшивання карнизів під штукатурку при кам'яних стінах, виступ карнизу більше 500 мм	93,21 ч	1 день	Вт 08.12.20

The calculator window shows the calculation: $1387,99 + 10 + 8 = 17,349,875$.

Figure 3.47 – Step 3 "Assignment of the required number of workers to the task to calculate the duration": calculate the required number of workers

The screenshot displays the Microsoft Project interface. The 'Task Information' dialog box is open, showing the 'Resources' tab. The task name is 'Улаштування крові і мауерплатів' (Roofing and eaves). The resource assigned is 'Рoofer' (Roofer) with 1800% units. The duration is 70.21 days. The background shows a Gantt chart with task bars for various construction tasks.

Название ресурса	Владелец назначения	Единицы	Затраты
Покрівельник	Рoofer	1800%	0,00 €

Figure 3.48 – Step 3 "Assignment of the required number of workers to the task to calculate the duration": assign the resource "Roofer" with the required number of workers in the window "Information about the task"

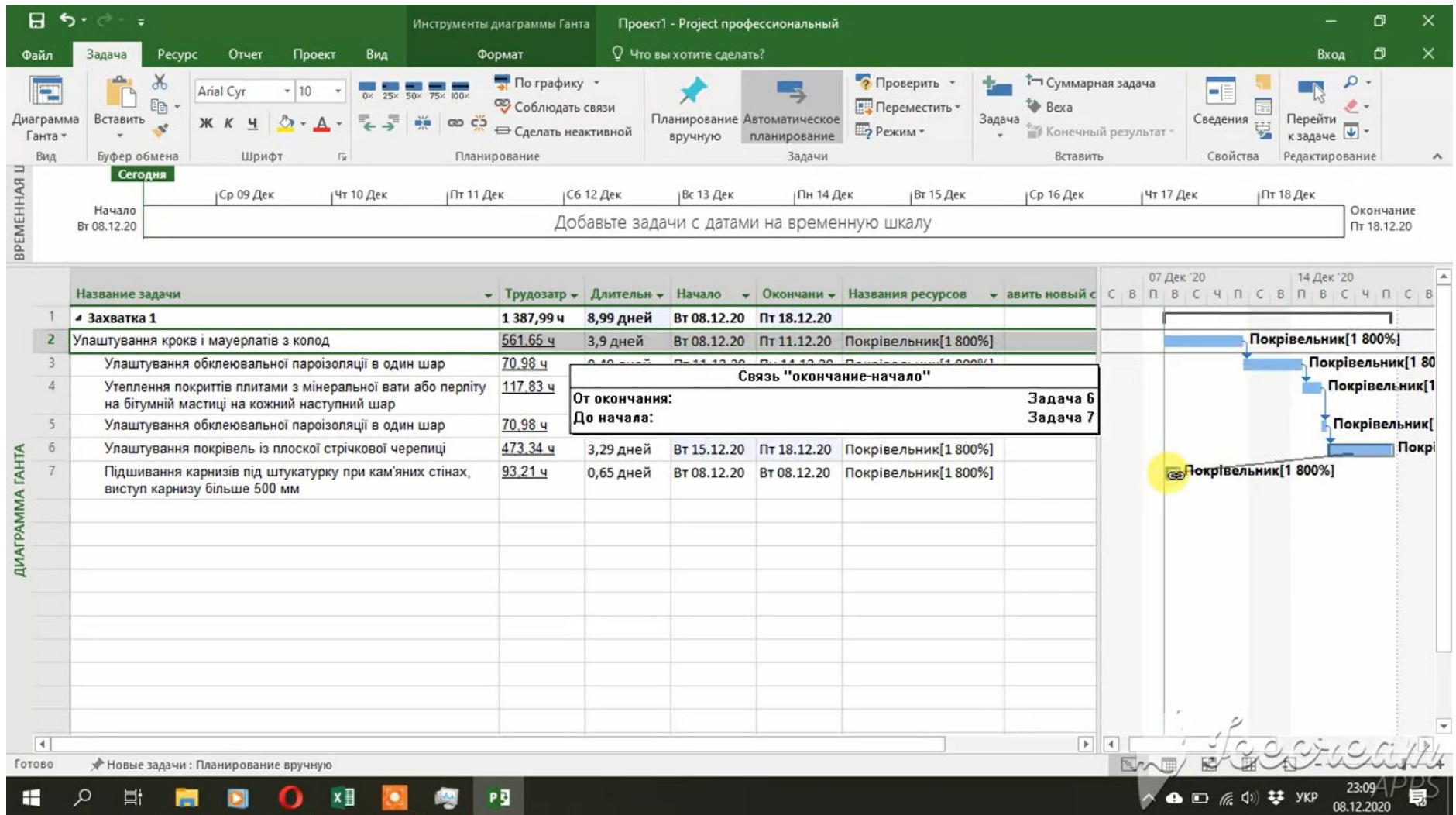

Figure 3.49 – Step 4 "Defining of technological connection of works": "drag" communication using the graphical part of the interface

3.5 Tables of material and technical resources need

To ensure the performance of works of any kind, it is necessary to supply the appropriate resources: workers, construction machines and equipment, building materials, products and structures. This section is devoted to calculating the need for material and technical resources, which do not include labor costs of workers. These costs are calculated as part of the calculation (table 3.1., subsection 3.3).

To quickly calculate the need for material and technical resources, it is possible to use the aggregated indicators contained in the normative document State Standard of Ukraine B D.2.4-8: 2012 "Resource element estimates for repair and construction work. Roofs (Collection 8)" [5]. The following are the specific costs of installing 100 m² of bituminous shingles: in table 3.4 – time consumption on construction machinery and equipment; in table 3.5 – consumption of building materials, products and structures. Aggregate indicators of resource consumption can be determined by multiplying the volume of roofing work by the specific consumption according to the tables.

Table 3.4 – Specific time spent on construction machines and equipment for the installation of 100 m² of bituminous shingles

Resource code according to DSTU B D.2.4-8: 2012	Name	Labor spent per 100 m ² , hours
CH202-970	The portable crane, loading capacity is 1 t	7.295
CH200-40	Electric bitumen boiler, capacity 1 m ³	7.86

Table 3.5 – Specific time spent on building materials, products and structures for the installation of 100 m² of bituminous roofing

Resource code according to DSTU B D.2.4-8: 2012	Name	Unit	Consumption per 100 m ²
1	2	3	4
Calculated separately	Bituminous shingles	m ²	110
Calculated separately	Mineral wool boards	m ³	21
Calculated separately	Vapor barrier film	m ²	110
Calculated separately	Spiked membrane	m ²	110
Calculated separately	PVC membrane	m ²	115
C111-78	Bitumen oil for roofing	t	0.025
C111-175	Construction nails with a conical head of 4,0x100 mm	t	0.00483

Continuation of table 3.5

1	2	3	4
C111-176	Construction nails with a conical head of 5,0x120 mm	t	0.005
C111-322	Kerosene for technical purposes	t	0.06
C111-594	Bituminous roofing mastic	t	0.593
C111-782	Forgings from square preparations, weight 1,8 kg	t	0.195
C111-822	Low-carbon black steel wire for various purposes, 1.6 mm	t	0.00109
C111-1762	Roofing felt with coarse-grained waterproofing powder	m ²	76.5
P111-1798	Galvanized steel sheet, thickness 0.7 mm	t	0.03
C111-1853-1	Construction nails 2,5x50 mm	t	0.0003
C111-1853-2	Construction nails 3,0x70 mm	t	0.0003
C111-1853-4	Construction nails 4,0x120 mm	t	0.006
C112-8	Timber round coniferous breeds for construction, length 3-6,5 m, diameter 14-24 cm	m ³	5
C112-49	Eaves boards from coniferous breeds, length is 4-6,5 m, width is 75-150 mm, thickness is 19,22 mm, III grade	m ³	0.25
C112-70	Unedged board from coniferous breeds, length is 4-6,5 m, thickness is 19,22 mm, IV grade	m ³	0.763
C112-86	Bars cut from coniferous breeds, length 2-3,75 m, width 75-150 mm, thickness 40-75 mm, IV grade	m ³	0.81
C112-142	Unedged board from coniferous breeds, length is 2-3,75 m, all widths, thickness is 44 mm and more, IV grade	m ³	0.56
C112-285	Edged whetstones of coniferous breeds, length is 2-6,5 m, thickness is 40-60 mm, II grade	m ³	0.112
C1113-292	Antiseptic paste	t	0.02
C1425-11687	Heavy cement-limestone solution, brand M25	m ³	0.25

Automated and more accurate calculation of the need for material and technical resources is also based on the aggregated indicators contained in the normative document State Standard of Ukraine B D.2.4-8: 2012 [5]. To do this, cost calculation programs can be used, for example AVK, MSmeta, "Estimate Technologies Smeta" and others. Here is an algorithm for calculating the cost of required resources on the example of the software package AVK-5 (3.0.0) – Fig. 3.50-3.51:

1. *Calculation of roofing works using bituminous shingles*: according to the algorithm in subsections 3.3(Fig. 3.35-3.43).
2. *Creating of resource statement*: open the menu "Output documents"; choose the item "Resource statement"; choose a convenient document format; copy sections "Construction machines and mechanisms" and "Building materials, products and structures" from the received document, data from columns 2-5.
3. *Calculation of consumption of recourses used*: manually calculate the cost of basic materials that are not taken into account by the estimated norms – bituminous shingles, mineral wool boards, vapor barrier film, spiked membrane, PVC membrane (specific costs to be accepted according to table 3.5).

3.6 Requirements for quality and acceptance of works

The main regulatory documents in terms of roofing are the following:

- State Building Code B.2.6-220: 2017 "Covering of buildings and structures" [6] – applies to the design of coatings of industrial and non-industrial buildings and structures and sets requirements for the structural composition of coatings, roofs, ventilation of combined and attic roofs, drainage and placement of equipment on roofs.
- State Standard of Ukraine-N B B.2.6-214: 2016 "Guidelines for the arrangement and operation of roofs of houses, buildings and structures" [7] – applies to the installation and operation of combined and attic roofs of industrial and non-industrial buildings; does not regulate the design and calculation of strength and thermal protection, installation of load-bearing structures.
- State Standard of Ukraine-N B A.3.1-23: 2013 "Guidelines for the installation of insulating, finishing, protective coatings on walls, floors and roofs of buildings and structures" [8] – applies to the production and acceptance of works on the installation of insulating, finishing, protective coatings (including roofs) and floors of buildings and structures, except for special operating conditions.

Ф127-1 АВК-5 (3.0.0) укр. Кошторисні документи

Створення Ресурси позицій, що виділені Параметри Вихідні документи Підсумок зведеного кошторисного розрахунку Повний екран Сервіс Вихід

Будова - (1) Курсовой проект ТСП СК 2 **Output documents**
Об'єкт - Коттедж

Ф214-0 АВК-5 (3.0.0) укр.

Будова - Курсовой проект ТСП СК 2
Об'єкт - Коттедж

Найменування вихідного документа Output documents	Шифр документа	Гаряча клавіша	Загальна вартість, грн.		Загальновиробничі витрати, грн.	
			заробітної плати	експлуатації машин у т.ч. заробітної плати		
Локальний кошторис, форма № 1	1_СД_ЛС1_2-1-2	Alt+Shift+6	16	1937	37	1625
Локальний кошторис (форма № 1) з розрахунком одиничної вартості	1_СД_ЛС1ЄС_2-1-2	Alt+Shift+7			33	
Локальний кошторис (форма № 1) з виділенням матеріалів	1_СД_ЛС1ВМ_2-1-2	Alt+Shift+J	62	580	4	457
Локальний кошторис (форма № 3) на пусконаладжувальні роботи	1_СД_ЛС3_2-1-2	Alt+A			4	
Дефектний акт	1_СД_ДФ_2-1-2	Alt+Shift+3	71	897	19	772
Розрахунки одиничної вартості	1_СД_ЛСКЛ_2-1-2	Alt+H			17	
Розрахунок загальновиробничих витрат	1_СД_ОПРЛС_2-1-2	Alt+I				
Витрати на доставку матеріалів, ресурсів, що розраховані калькуляц. методом	1_СД_ПЕРЛС_2-1-2	Alt+J	62	580	4	457
Відомість ресурсів Resource statement	1_СД_ВРЛС_2-1-2	Alt+K			4	
Підсумкова відомість ресурсів	1_СД_ИВРЛС_2-1-2	Alt+L	57	3732	54	3018
Зведення об'ємів	1_СД_В1_2-1-2	Alt+Shift+4			48	
Позиції локальних кошторисів, у яких змінені тільки найменування норм	1_СД_ИЗМ_2-1-2	Alt+Shift+X	07	1013	4	816
					3	

Виконати Перегляд документа Редагування шифру документа Друк документа Вихід

Витрати ресурсів:	на одиницю		усього		Разом по кошторису			
	матеріалів, грн.							
витрати труда робітників, не зайнятих обслуговуванням машин, люд.-г.		1377,30		6142	20475	8739	122	7334
витрати труда робітників, що обслуговують машини, люд.-год.		23,5		104,81			109	
		0,4692		2,09				

Figure 3.50 – Step 2 "Creating of resource statement": obtaining resource information

Ф016-0 АВК-5 (3.0.0) укр. 100% Пошук 6. СН202-970 Кран переносний, вантажопідйомність 1 т

Програмний комплекс АВК-5 (3.0.0) -1- 1_сд_ВРЛС_2-1-2

Курсовой проект ТСП СК 2

Resource statement Форма № 1а

Відомість ресурсів до локального кошторису № 2-1-2
на Кровельные работы

№ п/п	Шифр ресурсу	Найменування	Одиниця виміру	Кількість	Поточна ціна за одиницю, грн.	у тому числі:		
						відпускна ціна, грн.	транспортна складова, грн.	Заготівельно-складські витрати, грн.
1	2	3	4	5	6	7	8	9
I. Витрати труда								
1	1	Витрати труда робітників-будівельників	люд.-год	454,25	19,24			
2		Середній розряд робіт, що виконуються робітниками-будівельниками	розряд	3,3				
3		Витрати труда робітників, зайнятих керуванням та обслуговуванням машин	люд.-год	6,94	15,56			
4		Середній розряд ланки робітників, зайнятих керуванням та обслуговуванням машин	розряд	3,4				
5		Витрати труда робітників, заробітна плата яких враховується в складі:						
5.1		загальновиробничих витрат	люд.-год	55,34	32,33			
Разом кошторисна трудомісткість			люд.-год	516,53				
Середній розряд робіт			розряд	3,3				
II. Будівельні машини і механізми								
6	СН202-970	Кран переносний, вантажопідйомність 1 т	маш.-год	6,81113	17,83			
III. Будівельні машини, враховані в складі загальновиробничих витрат								

1/2

Figure 3.51 – Step 2 "Creating of resource statement": output resource information in the required format

- State Standard of Ukraine-N B B.2.6-203: 2015 "Guidelines for the performance of works in the manufacture and installation of building structures" [9] – establishes technical requirements for the installation of load-bearing structures, contains recommendations for the choice of materials, installation of wooden structures; does not apply to the installation of steel structures.

Recommendations for choice of materials and requirements for design of bituminous roofing are set out in subsection 7.6 of State Building Code B.2.6-220: 2017 [6].

According to State Standard of Ukraine-N B B.2.6-214: 2016 [7], quality control of works on arrangement of coverings and roofs of objects can provide the following: input control of design and technological documentation; input control of materials; operational quality control of work performed; acceptance control. At operational control it is recommended to carry out:

- determination of the consumption of primer, mastic, paint per 1 m² of surface;
- determination of the thickness of the paint waterproofing layer;
- instrumental check of coincidence of watershed ridges with building axes and height differences (slope) from watershed ridges to funnels;
- determination of the slope of the roof layer;
- determination of the thickness of the thermal insulation layer;
- determination of the size and straightness of ventilation ducts;
- determination of screed thickness;
- determination of width of the strip substrates and size of the gaps between them;
- determination of the size in the plan and the thickness of the additional layers;
- determination of the size of the allowance in the joints of the panels, the location of the joints, the strength of the gluing,
- melting temperature or solvent consumption when gluing roofing materials;
- determination of the size of the gaps in the joints of the panels, the strength of the gluing of roofing membranes;
- determination of the grain size of the bulk material and the thickness of backfill;
- determination of the thickness of the adhesive layer of mastic;
- determination of the sizes of elements of rafter system and laths;
- determination of the size of the roofing elements and eaves.

Technological deviations for installation of steam and thermal insulation of attic roofs are regulated by table 6.1 of State Standard of Ukraine-N B B.2.6-214: 2016 [7] (table 3.6). Installation of a rafter system of attic roofs from wood should be carried out by the enlarged volume blocks or a element-by-element way of assembly. Installation of volume blocks should be carried out on the fixed supporting elements (mauerlats, risers, etc.). It is desirable that the slinging scheme for lifting and installation of

three-dimensional blocks provides strength, stability of their geometric dimensions and shapes. In the element-by-element method, the installation of elements should be performed after the installation of the supporting part of the rafter system, wind ties and other elements that ensure the stability of the three-dimensional frame on the gripper (at least four rafter trusses). It is desirable that the surface of the base under the roof was smooth. Check the levelness of surface should be carried out with measuring rail.

The operational quality control scheme is proposed in Annex A of State Standard of Ukraine-N B B.2.6-214: 2016 [7], table A.2 (table 3.7).

Table 3.6 – Requirements during steam and thermal insulation arrangement of attic roofs

Technical requirements	Marginal deviations	Control method
Vapor barrier		
Deviations of surface equality of basis, no more	± 5 mm	Visual and three-meter control rail, at least 5 measurements per 100 m ² of surface
Thickness of mastic vapor barrier and adhesive layers of mastic rolled vapor barrier, not more	$\pm 10\%$ of the project	Consumption of mastic per unit area of the probe with a scale interval of not more than 1 mm
Thermal insulation		
Base moisture, no more	5% by weight	Laboratory control
Thickness of a heat-insulating layer, no more	-10% of the project	Roulette, at least 5 measurements per 50 m ² of surface

Table 3.7 – Operational scheme of quality control of attic roofs for State Standard of Ukraine-N B B.2.6-214: 2016 [7]

Subject of control	Stages of control	Methods of control
1	2	3
1 Provision of initial conditions for roofing		
Completion of installation of attic floor structures	Input	Visually. Registration of the permission for the beginning of roofing works
Compliance of quality of products and materials with the requirements of current regulations		Regulatory documents for construction products and materials

Continuation of table 3.7

1	2	3
2 Readiness of bases		
Cleanliness of the base for vapor barrier	Input	Visually
Equality of a basis under thermal insulation		Instrumental rail and metal ruler according to State Standard of Ukraine 427
Cleanliness of the base under the roof		
3 Quality of installation of vapor barrier layers		
Correctness of arrangement of layers of painting vapor barrier	Operating	Visually. Measurement of thickness of the layer with a caliper according to State Standard of Ukraine 166 or 8925
Correctness of arrangement of layers of gasket vapor barrier		Visually. Measurement of thickness of the layer with a caliper according to State Standard of Ukraine 166 or 8925
4 Quality of installation of heat-insulating layers		
Correctness of heat-insulating layer from plate heaters	Operating	Measurement of thickness of a heat-insulating layer by a metal ruler in accordance with State Standard of Ukraine 427
Correctness of heat-insulating layer from monolithic heaters		
Correctness of heat-insulating layer from loose heaters		
5 Quality of the arrangement of a basis under a roof		
Correctness of the arrangement of a coupler from a cement-sandy solution	Operating	Visually. Measurement of the thickness of the screed with a metal ruler according to State Standard of Ukraine 427
Correctness of the arrangement of reinforced concrete runs		Visual
Correctness of the arrangement of elements of wooden plates		

1	2	3
6 Quality of roof installation		
Correctness of the arrangement of a roof from fiber-cement corrugated sheets	Operating	Visually. The presence of sealing joints. Measurement of the size of the roofing elements and eaves overhangs with a metal ruler according to State Standard of Ukraine 427
Correctness of the arrangement of a roof from a tile		Visually, the presence of sealing joints. Measurement by meter of the value of the allowance and overhangs with a metal ruler according to State Standard of Ukraine 427
Correctness of the arrangement of a roof from galvanized steel		
7 Quality of arrangement of details and knots		
Arrangement of roof connections to the protruding parts	Operating	Visually. Establishing reliability of fastening of aprons, collars, caps, etc. and sealing of seams and connections
Sealing of places of passage of pipes, risers and other details through a roof		Visually. Determining the presence of sealing seams and the reliability of the fastening of drainage devices
8 General condition of the finished roof		
Technical condition of the roof surface	Acceptance	Visually. 3 fixation of defects (bulges, inflows, chips, cracks, exfoliation, cracks in the joints of roofing elements) in the statement of defects
Technical condition of roof connections, arrangement of protruding parts and details		Visually. 3 fixing of defects (swinging in fastening of details, aprons, ridges, gable and eaves overhangs, exfoliation in places of sealing) in the statement of defects

1	2	3
Technical condition of the drainage system	Acceptance	Visually. Check of reliability of a drain by 3 control tests (return bias in catchment trays, swinging in fastening of drainage pipes, lack of density of connection of links of drainage pipes) in the statement of defects

Preparation of bases and below placed elements of isolation is regulated by table 2 of State Standard of Ukraine-N B A.3.1-23: 2013 [8] (table 3.8).

Table 3.8 – Requirements to preparation of bases and insulation elements

Technical requirements	Marginal deviations	Control (method, scope, type of registration)
Permissible deviations of the base surface in roll and roll-free emulsion and mastic insulation and roof: along the slope and on a horizontal surface	± 5 mm	Measuring, technical inspection, not less than 5 measurements on each 70-100 m ² of a surface or on a site of smaller area in the places defined by visual inspection
across the slope and on a vertical surface	± 10 mm	
of artificial materials: along and across the slope	± 10 mm	
Deviation of the plane of the element from a given slope (over the entire area)	0.2%	
Thickness of a structural element (from design)	10%	
The number of irregularities (smooth outline with a length of not more than 150 mm) on the surface area of 4 m ²	not more than 2	
Primer thickness, mm: for roofs made of surfacing materials	5%	
when priming the hardened screed	5%	
when priming screeds for 4 h after application of the solution	10%	

According to State Standard of Ukraine-N B B.2.6-203: 2015 [9], when performing work on warehousing, transportation, storage and installation of wooden structures should take into account their specific features:

- the need for protection from prolonged weathering, in connection with which the work should include, as a rule, installation of the building on the grips, which includes the sequential erection of load-bearing structures, enclosing structures and roofs in the short term;
- the minimum possible number of operations for tilting and relocation of wooden structures during loading, unloading and installation.

Structures or their elements treated with salt-based flame retardants should be stored in conditions that protect the structures from wetting and leaching of salts. When wooden structures come into contact with brickwork (soil, monolithic concrete, etc.), insulation work must be performed before installation. The accuracy of construction and installation deviations should not exceed those specified in table 12 of State Standard of Ukraine-N B B.2.6-203: 2015 [9] (table 3.9).

Table 3.9 – Maximum deviations of installation of wooden elements

Technical requirements	Marginal deviations	Control (method, volume, type of registration)
Deviation of the depth of the cut from the design	± 2 mm	Measuring, each element
Deviations in distances between the centers of working bolts, nails, dowels in connections concerning design: for inlets	± 2 mm	Measuring, selective
for outlets across the fibers	2% of the thickness of the package, but not more than 5 mm	
for outlets along the fibers	4% of the thickness of the package, but not more than 10 mm	
Deviation in the distances between the centers of the nails from the side of driving in the nail joints	± 2 mm	
Deviation of faces: crowns of chopped walls from horizontal on 1 m of length and walls of partitions from the vertical to 1 m in height	± 3 mm	Measuring, in each wreath

3.7 Safety and labor protection, environmental and fire safety

Roofing work performing should comply with the requirements of the following basic regulations:

- State Standard of Ukraine-N B A 3.2-1: 2007 "Guidelines for the identification of hazardous and harmful factors and protection against their impact in the production of building materials and products and their use in the construction and operation of construction projects" [10] – contains a list of major hazardous and harmful factors that occur in construction, and recommendations for their detection and prevention.
- State Building Code A.3.1-5: 2016 "Organization of construction production" (sections 5 and 7) [3] – contains general requirements and recommendations for the organization of the roofing process and appropriate measures for labor protection and industrial safety.
- State Building Code A.3.2-2-2009 "System of labor safety standards. Occupational safety and industrial safety in construction. Substantive provisions" (in particular, section 17) [11] – determines the requirements for labor protection and industrial safety during construction and installation work.
- State Standard of Ukraine B A.3.2-11: 2009. SSBP. "Roofing and waterproofing works. Security requirements" [12] – determines the requirements for labor protection and industrial safety during the performance of roofing works. The guidelines set requirements for technological processes, production equipment and production sites, organization of workplaces, storage and transportation of materials, use of personal protective equipment.
- Normative Legal Act on Labor Protection 0.00-1.15-07 "Rules of labor protection during work at height" [13].
- Normative Legal Act on Labor Protection A.01.001-2004 "Rules of fire safety in Ukraine" [14].

According to State Standard of Ukraine-N B A 3.2-1: 2007 [10], the main dangerous and harmful factors that occur in construction are radiation and fire hazards, factors of negative impact on human production and non-production environment (air quality, indoor climate, humidity, lighting, operational safety, noise, static electricity), hazardous waste and other. Also, this list can be expanded due to such factors as the height of the work, the use of large lifting mechanisms and electrical equipment and tools. When organizing work and labor protection measures, it is important to carefully analyze all possible dangerous and harmful factors and perform appropriate design, in particular – in the technological map.

Persons at least 18 years of age who have been trained in safe methods and techniques of performing these works, who have received the appropriate certificate and have been instructed in the workplace, are allowed to arrange roofing work. Extraordinary safety training is carried out when roofing workers move from one type of roof to another, when changing the conditions of work, violations of rules and instructions on safety. Admission of workers to roofing works is allowed only after inspection by a foreman or together with the head of serviceability and integrity of load-bearing structures of coatings and fences.

Areas of permanent hazardous production factors include: pitched roofing with an angle of more than 20 °; area of supply and reception of roofing materials. The area of potentially dangerous hazardous production factors is the area of the construction site located on the perimeter of the building on the roof of which work is underway.

Roofing is not allowed during ice, fog, which eliminates visibility within the front of the work, thunderstorms and wind with a speed of 15 m/s and more. Managers of the construction organization are obliged to organize timely notification of the specialized unit that performs roofing work, about sudden changes in weather (hurricane wind, thunderstorm, snowfall, etc.).

All persons on the construction site are required to wear protective helmets. When working on roofs with a slope of more than 20 °, workers must use seat belts. Places of fastening of belts are specified by the master. Roofers should wear rubber shoes to reduce the slippage of the feet on the roof during work.

Coating materials must be procured in a technological sequence that ensures the safety of work. When supplying roofing materials to the crane, slinging loads should be performed only with inventory slings. Elements and details of roofs, including protective aprons, links of drains, ebbs, etc. must be submitted to the workplace in the prepared form. Procurement of these elements and parts directly on the roofs is not allowed.

It is allowed to place materials on roofs only in the places provided by the project of performance of works, with acceptance of measures against falling, including from influence of wind. During breaks in work, technological devices, tools and materials must be fixed or removed from the roof. It is forbidden to drop materials and tools from the roof.

Around the perimeter of the part of the buildings on which the roof is covered or repaired, the marks should be placed on the boundary of the danger zone for people. The width of such a zone must be at least 3 m from the wall of the building. The border of the danger zone is marked with signal tapes, signs, inscriptions, which are installed on the risers.

Installation of caps and umbrellas on the heads of chimneys and ventilation pipes should be performed from scaffolding. It is forbidden to use additional ladders for these purposes.

In case of a fire at construction site, each worker must immediately notify the fire brigade, take all measures to evacuate people and save property and begin to extinguish the fire with the fire extinguishers available at the construction site. When extinguishing flammable liquids, the jet of extinguishing agent should be directed to the edge of the area covered by the fire, gradually covering its entire surface. If hot mastic gets on the skin, it should be washed off with gasoline, and then a compress should be put of potassium permanganate or baking soda on the burned area and worker should go to the emergency room.

3.8 Technical and economic indicators

Technical and economic indicators are based on the calculation of labor costs and work schedule. The composition of technical and economic indicators and the formulas of their calculations are set out in table 3.10.

Table 3.10 – Technical and economic indicators of roofing production

Characteristic	Unit	Initial data and calculation formula
1	2	3
Labor costs for the entire scope of work	days	based on the calculation (table 3.1)
Costs of machine time for the entire scope of work	days	based on the calculation (table 3.1)
Wages of workers	UAH	based on the calculation (table 3.1)
Wages of mechanics	UAH	based on the calculation (table 3.1)
Duration of work	days	on schedule (subsection 3.4)
Production of one worker per shift	m ² /days	$B_p = \frac{S}{\sum T},$ where: S – total roof area, m ² ; $\sum T$ – total labor costs of workers in accordance with the final line of column 12 of the calculation (numerator).
Labor costs per 1 m ² of roof	days/m ²	$T_e = \frac{\sum T}{S}$

Continuation of table 3.10

1	2	3
Labor costs of drivers per 1 m ² of roof	days/m ²	$t_{\text{МАШ}} = \frac{\sum T_{\text{МАШ}}}{S},$ where: $\sum T_{\text{МАШ}}$ – total labor costs of drivers to the final line of column 12 of the calculation (denominator).
The cost of labor per 1 m ² of roof	UAH/m ²	$C_e = \frac{C}{S},$ where: C – total cost of labor costs (UAH).

REFERENCES

1. State Standard of Ukraine 3008 95. Information and documentation. Re-ports in the field of science and technology. Structure and design rules. Kyiv: Ukrainian Research and Training Center of Standardization, Certification and Quality, 2016.
2. State Standard of Ukraine B B.2.6-189: 2013. Methods of choosing thermal insulation material for building insulation. Kyiv: State Research Institute of Building Constructions, 2014.
3. State Building Code A.3.1-5-2016. Organization of construction production. Kyiv: State Research Institute of Building Production, 2017.
4. Guide to State Building Code A.3.1-5-96 on the development of construction organization project and works execution project. Kyiv: NDIBV, 1997. 125 p.
5. State Standard of Ukraine B D.2.4-8: 2012. Resource element estimates for repair and construction work. Roofs(Collection 8). Kyiv: Research Institute "Inproject", 2014.
6. State Building Code B.2.6-220: 2017. Covering of buildings and structures. Kyiv: State Research Institute of Building Production, 2018.
7. State Standard of Ukraine-N B B.2.6-214: 2016. Guidelines for the arrangement and operation of roofs of houses, buildings and structures. Kyiv: State Research Institute of Building Production, 2017.
8. State Standard of Ukraine-N B A.3.1-23: 2013. Guidelines for the installation of insulating, finishing, protective coatings on walls, floors and roofs of buildings and structures". Kyiv: State Research Institute of Building Production, 2013.
9. State Standard of Ukraine-N B B.2.6-203: 2015. Guidelines for the performance of works in the manufacture and installation of building structures. Kyiv: State Research Institute of Building Production, 2016.
10. State Standard of Ukraine-N B A 3.2-1: 2007. Guidelines for the identification of hazardous and harmful factors and protection against their impact in the production of building materials and products and their use in the construction and operation of construction projects. Kyiv: State Research Institute of Building Production, 2007.
11. State Building Code A.3.2-2-2009. Occupational safety standards system. Occupational safety and industrial safety in construction. Substantive provisions. Kyiv: State Research Institute of Building Production, 2012.

12. State Standard of Ukraine B A.3.2-11: 2009. Roofing and waterproofing works. Security requirements. Kyiv: Ministry of Regional Development of Ukraine, 2010.
13. Normative Legal Act on Labor Protection 0.00-1.15-07 "Rules of labor protection during work at height". Kyiv: Ministry of Justice of Ukraine, 2007.
14. Normative Legal Act on Labor Protection A.01.001-2004. Fire safety rules in Ukraine. Kyiv: Ministry of Justice of Ukraine, 2004.
15. State Standard of Ukraine BV2.7.-101-2000. Roll roofing and water-proofing materials. General technical conditions. Kyiv: MNTKB, 2000.
16. Modern technologies of the arrangement of roofs. Meneilyuk A.I., Lukashenko L.E., Kozlyuk E.I., Moskalenko V.I., Petrovsky A.F. Kharkiv: EDENA LLC, 2006. 288 p.
17. Roofing works. Edited by Livinsky O.M. Kyiv: MP Lesya, 2008. 276 p.
18. Methodical instructions for the course work in the discipline: "Application of new technologies in construction". Compilers: Meneilyuk A.I., Lukashenko L.E., Odessa: Odesa State Academy of Civil Engineering and Architecture, 2007.
19. Modern technologies in construction. Meneilyuk A.I., Dorofeev V.S., Lukashenko L.E., Oleynik N.V., Kyiv: Education of Ukraine, 2010. 550 p.
20. State Building Code B.1.1.7-2002. Fire protection. Fire safety of construction sites. Kyiv: Ukrainian Research Institute of Fire Safety, 36 p.

APPENDIX A. EDUCATIONAL VIDEO CLIPS FOR CREATING CALCULATIONS AND SCHEDULES

Creating a calculation in the AVC program:

<https://drive.google.com/file/d/1Eoz75bUX-OddKdCFqQbSIpgbzIwyDS3Ho/view?usp=sharing>

Scheduling in Microsoft Project:

https://drive.google.com/file/d/1MnBYZ-HSi3CaSymHffUi-7g1RcDPKv_R/view?usp=sharing

Output of the calculation from the AVC program and preparation for copying in Microsoft Project:

<https://drive.google.com/file/d/1XidiW39uiNEB04aa3JK9oqw8bu6mwj09/view?usp=sharing>

Graph output from Microsoft Project:

<https://drive.google.com/file/d/179SynlRy4Arp5iU3MXbtO4XQiyh2ZWxx/view?usp=sharing>

APPENDIX B. EXAMPLE OF A GRAPHIC PART OF A TECHNOLOGICAL MAP

The scheme of production of works on the arrangement of a roof S1220

OSABA ICB-463

2-storey brick house

Ch. Sheet	№ docum.	Signature	Date
Done by	Chernetskaya		
Checked by	Nikiforov		

Technical maps on establishment covering from asphalt single and establishing floor from laminate on a base of gypsum fiber sheets	Stage	Sheet	Sheets
	S	1	2

Department of Construction Technology

Instructions for work and safety

All persons on the construction site are required to wear protective helmets. Before starting work, it is necessary to calculate the required amount of materials. All used equipment and tools must be in good condition. Work on faulty equipment or using faulty tools is prohibited. Housings of all mechanisms, manual electric machines must be grounded. The cable connections must be insulated. Percussion instruments must be securely mounted on oval handles with a thickened free end and secured with metal or wooden clips. After finishing work it is necessary to switch off power tools, to clear the manual tool and to put it in a tool box, to clean a workplace, waste from materials used must be removed from the site. When carrying or transporting the tool, its sharp parts must be covered with covers.

Technical and economic indicators

№	Indicator name	Unit	Number
1	Duration of work	days	9-12
2	Labor costs of workers	man-hours	2400-26
3	Cost of material	rubles	6-10
4	Cost of machine	man-hours	6-10
5	Speed of machine per unit of measurement	man-hours/m ²	0.07
6	Production of one worker per day	m ² /man-day	2-11
7	Cost of labor per unit of measurement	rubles/m ²	35-7
8	Wage of machine operator	man-hours	10-15
9	Weight of materials	kg	4500-65

The need for material and technical resources

№	Resource name	Indicator name	Unit	Number
1	Excavator	Building machines and mechanisms	man-hours	2-376
2	Excavator	Fitted vehicles, carrying capacity 5 t	man-hours	6-159
3	Excavator	Tractor, lifting capacity 5 t	man-hours	30-529
4	Excavator	Portable crane, lifting capacity 1 t	man-hours	2-178
5	Excavator	Building machines, included in general production costs	man-hours	2-178
6	Excavator	Electric blower, capacity 1 m ³	man-hours	52-118
7	Excavator	Construction nails with tapered head 4.0x200 mm	t	0-105
8	Excavator	High friction cord, diameter 10 mm	m	3-102
9	Excavator	Forgings from square blanks, weight 18 kg	t	0-192
10	Excavator	Low-carbon steel wire for various purposes, black	t	0-087
11	Excavator	Steel-wound waterproofing roofing paper, grade 16-300	m ²	885-3
12	Excavator	Construction nails, thickness 0.3 mm	t	0-109
13	Excavator	Construction nails, 2.5x50	t	0-102
14	Excavator	Construction nails, 3.0x70	t	0-102
15	Excavator	Construction nails, 4.0x120 mm	t	0-104
16	Excavator	Round softwood timber for construction, length 6.5 m	m ³	12-1
17	Excavator	Round softwood timber for construction, length 6.5 m, width 25-50 mm, thickness 19-22 mm, grade III	m ³	0-666
18	Excavator	Round softwood timber for construction, length 6.5 m, width 25-50 mm, thickness 19-22 mm, grade IV	m ³	2-386
19	Excavator	Round softwood timber for construction, length 6.5 m, width 25-50 mm, thickness 19-22 mm, grade V	m ³	5-3-1
20	Excavator	Round softwood timber for construction, length 6.5 m, width 25-50 mm, thickness 19-22 mm, grade VI	m ³	3-691
21	Excavator	Concrete reinforcement bars, length 2.375 m, width 2.375 m, all widths, thickness 4.5 mm and more, IV	m ³	0-35
22	Excavator	Concrete reinforcement bars, length 2.375 m, width 2.375 m, all widths, thickness 4.5 mm and more, IV	m ³	0-109
23	Excavator	Concrete reinforcement bars, length 2.375 m, width 2.375 m, all widths, thickness 4.5 mm and more, IV	m ³	0-109
24	Excavator	Energy carriers of machines, suitable to general production costs	kg	896-944
25	Excavator	Lubricants	kg	11-173

Stages of installation

- Insulation of ceilings or perlitte on bitumen mastic for each subsequent layer
- Vapor barrier gluing arrangement in one layer
- Sewing cornice for plaster on stone walls, relative to the cornice is more than 500 mm
- Installation of roofing from flat tape shingles
- Sewing cornice for plaster on stone walls, relative to the cornice is more than 500 mm

Calendar schedule of works

№	Task Name	Labor Duration	Start	End	Resources Name
1	Insulation of ceilings	100-59 h	01.12.2022	04.01.2023	Reofer (1.7096)
2	Insulation of ceilings	100-59 h	01.12.2022	04.01.2023	Reofer (1.7096)
3	Insulation of ceilings	100-59 h	01.12.2022	04.01.2023	Reofer (1.7096)
4	Insulation of ceilings	100-59 h	01.12.2022	04.01.2023	Reofer (1.7096)
5	Insulation of ceilings	100-59 h	01.12.2022	04.01.2023	Reofer (1.7096)
6	Insulation of ceilings	100-59 h	01.12.2022	04.01.2023	Reofer (1.7096)
7	Insulation of ceilings	100-59 h	01.12.2022	04.01.2023	Reofer (1.7096)
8	Insulation of ceilings	100-59 h	01.12.2022	04.01.2023	Reofer (1.7096)
9	Insulation of ceilings	100-59 h	01.12.2022	04.01.2023	Reofer (1.7096)
10	Insulation of ceilings	100-59 h	01.12.2022	04.01.2023	Reofer (1.7096)
11	Insulation of ceilings	100-59 h	01.12.2022	04.01.2023	Reofer (1.7096)
12	Insulation of ceilings	100-59 h	01.12.2022	04.01.2023	Reofer (1.7096)
13	Insulation of ceilings	100-59 h	01.12.2022	04.01.2023	Reofer (1.7096)
14	Insulation of ceilings	100-59 h	01.12.2022	04.01.2023	Reofer (1.7096)

SCOPE

This technological map is developed for performance of works on the arrangement of a roof from asphalt shingle. For a 2-storey brick building with a roof area of 26.5x26.5 m. The roof is divided into two beams, one of sixteen and one of sixteen and one of sixteen people, so as to have time to complete all production operations in 14 working days. Deviations from the delivery deadline are not dropped.

APPENDIX B. EXAMPLE OF THE DESIGN OF THE TITLE PAGE
MINISTRY OF EDUCATION AND SCIENCE OF UKRAINE
ODESA STATE ACADEMY OF CIVIL ENGINEERING AND
ARCHITECTURE

DEPARTMENT OF CONSTRUCTION PRODUCTION TECHNOLOGY

EXPLANATORY NOTE

to the course project (work)

from the discipline:

"Technology of construction production (special course) 2"

Technological map on the topic _____

EXECUTED BY: student of group _____

CHECKED BY: _____

SCOPE OF CP (CW):

pages of the note _____

graphic part _____

Odesa – 20__.

APPENDIX D. VARIANTS OF TASKS

SCHEME 1

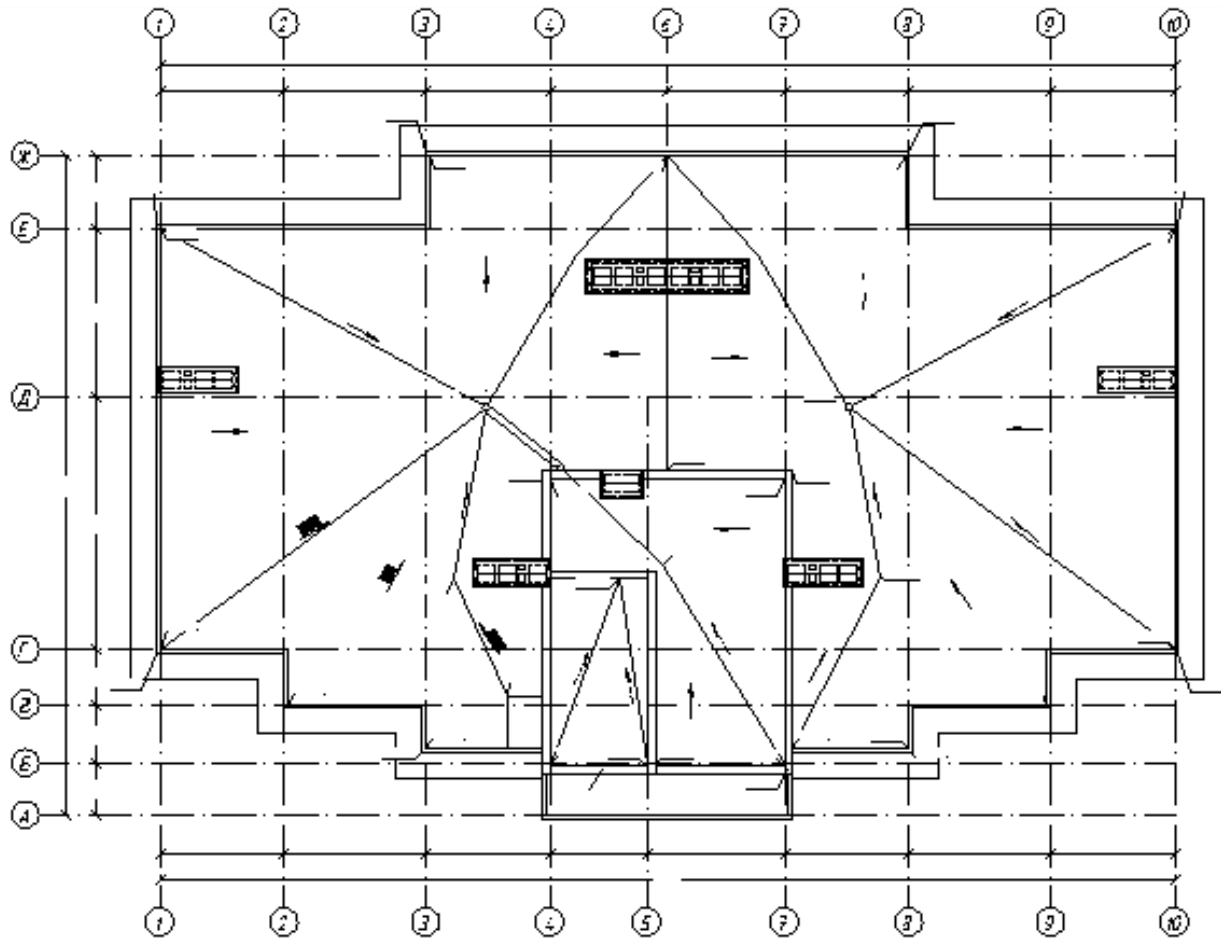

SCHEME 2

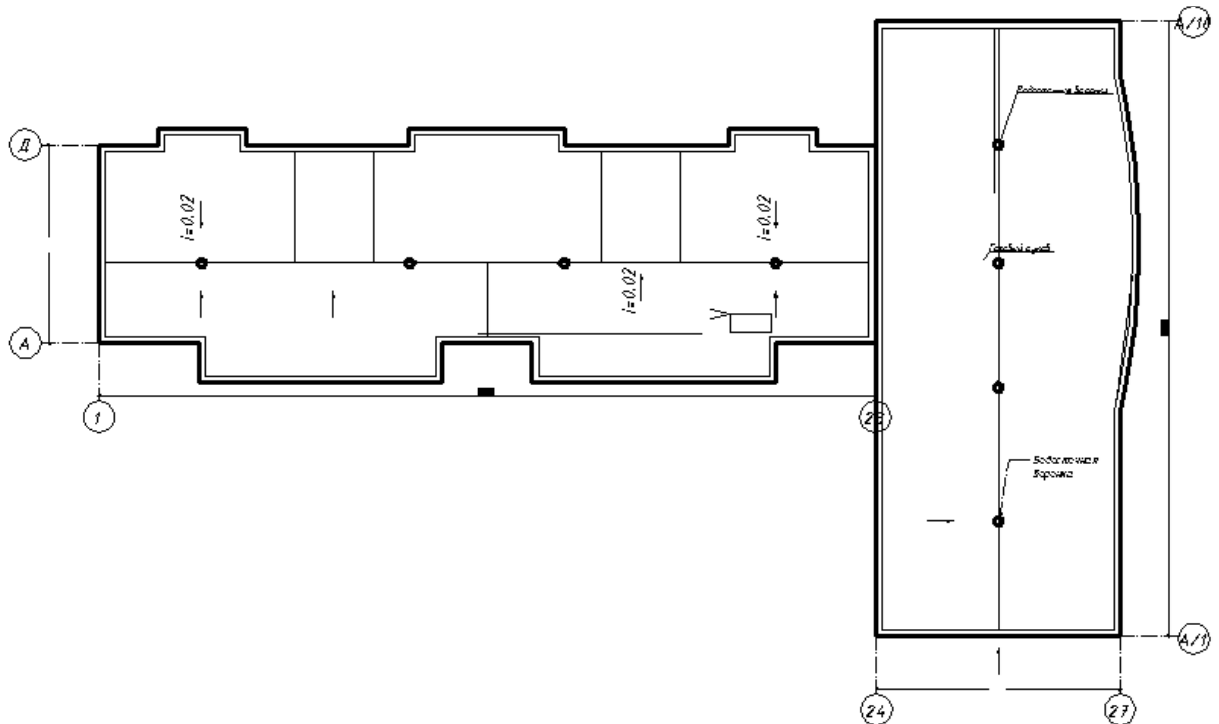

SCHEME 3

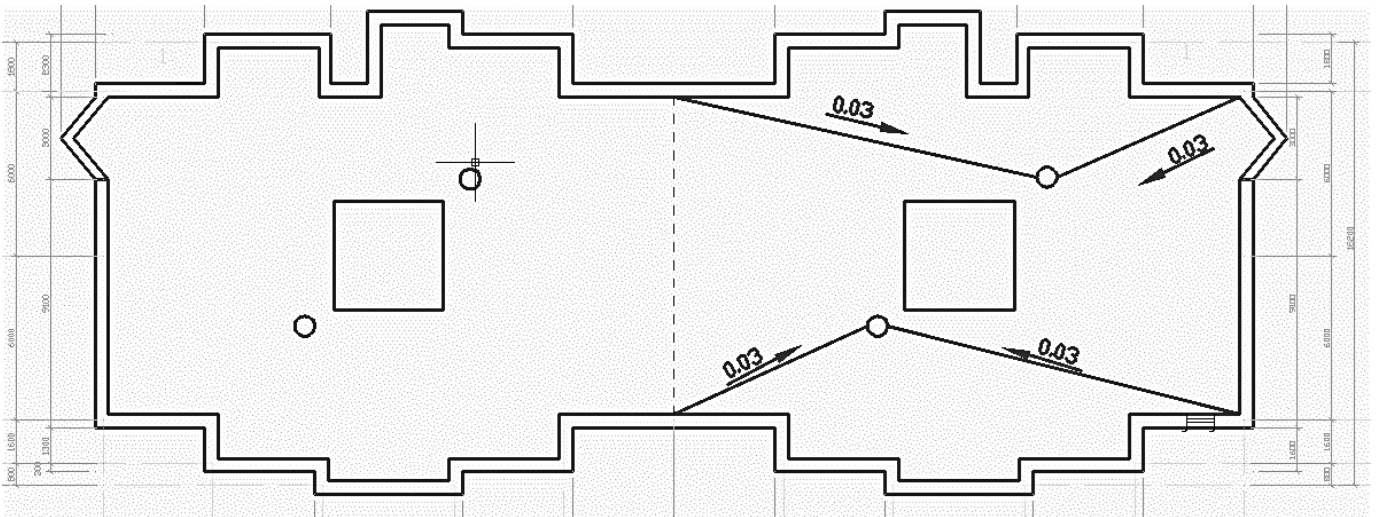

SCHEME 4

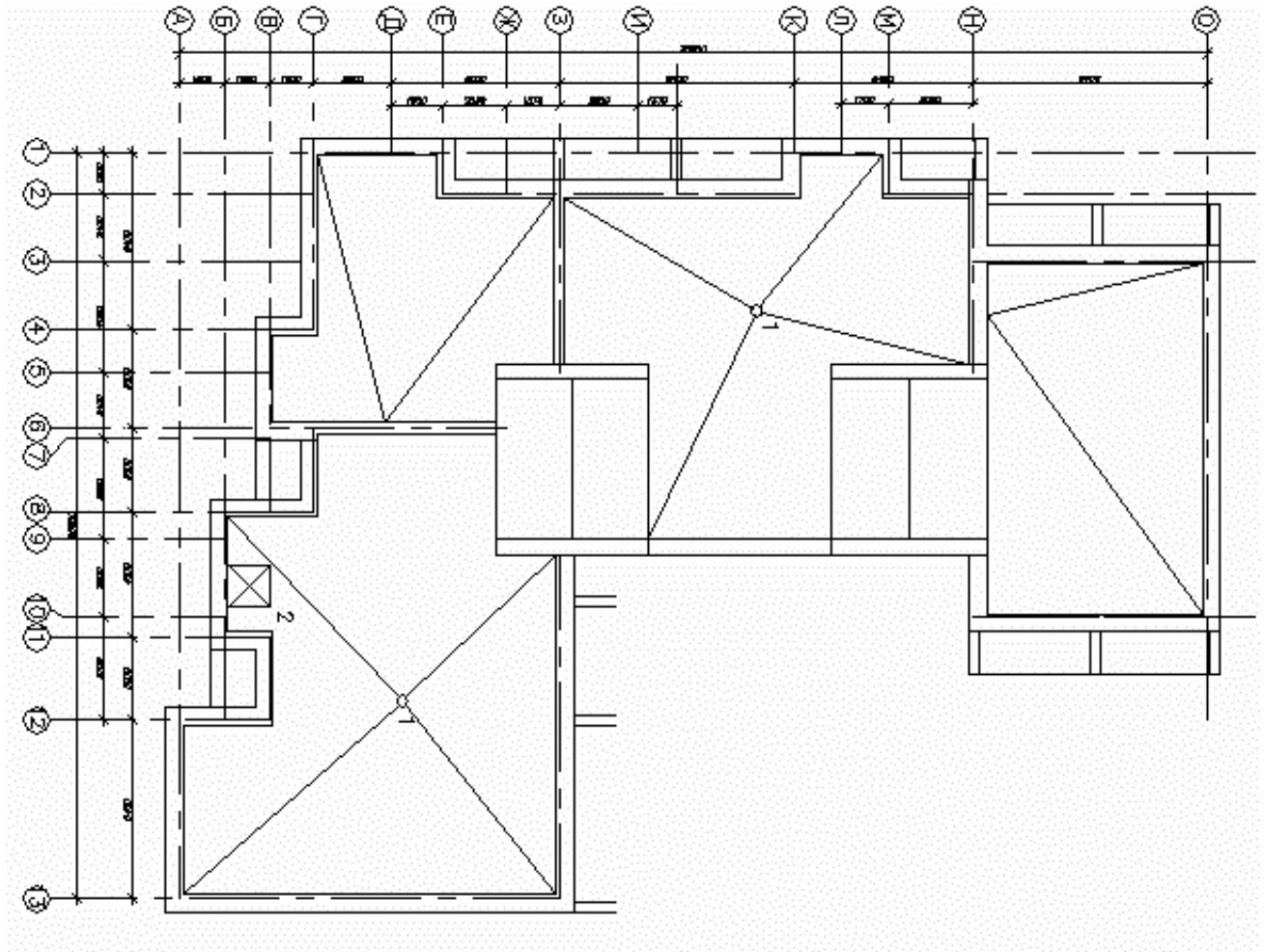

SCHEME 5

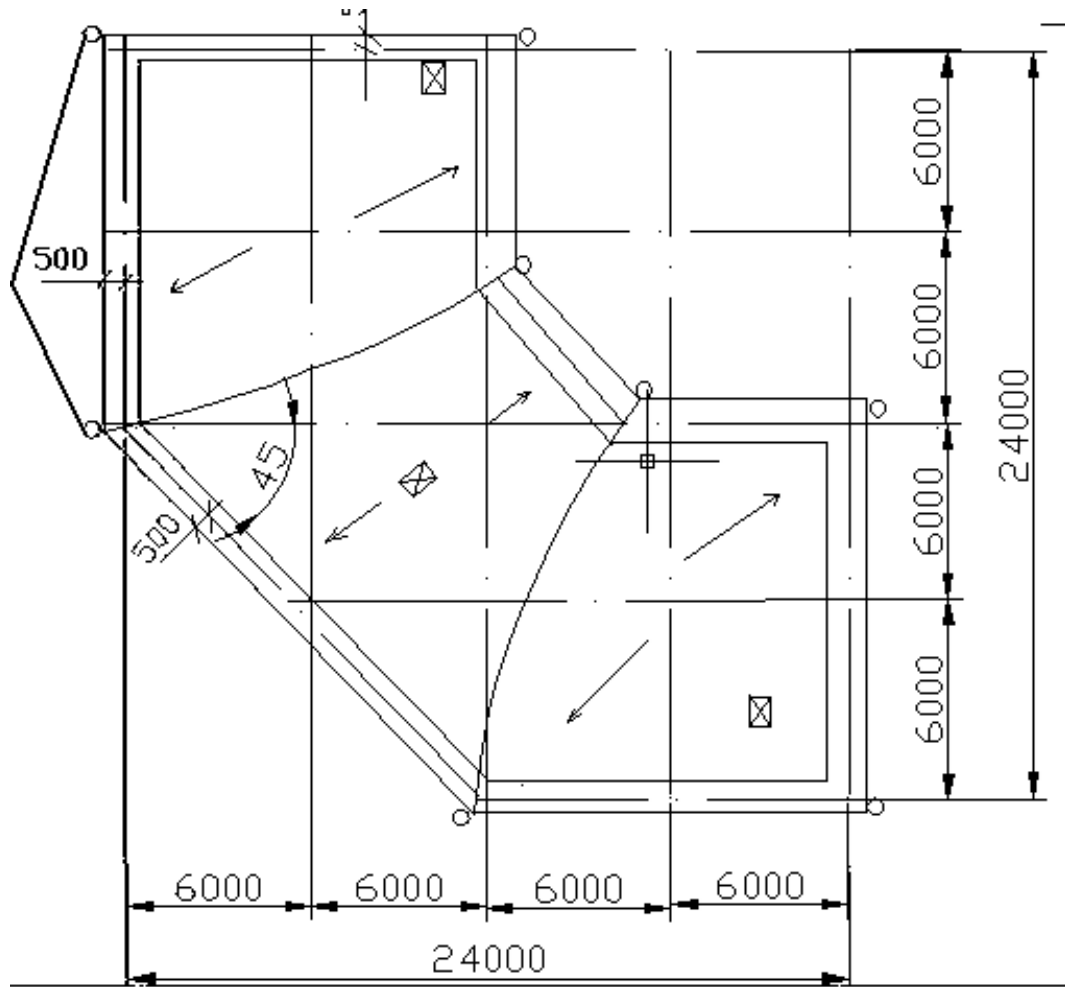

SCHEME 6

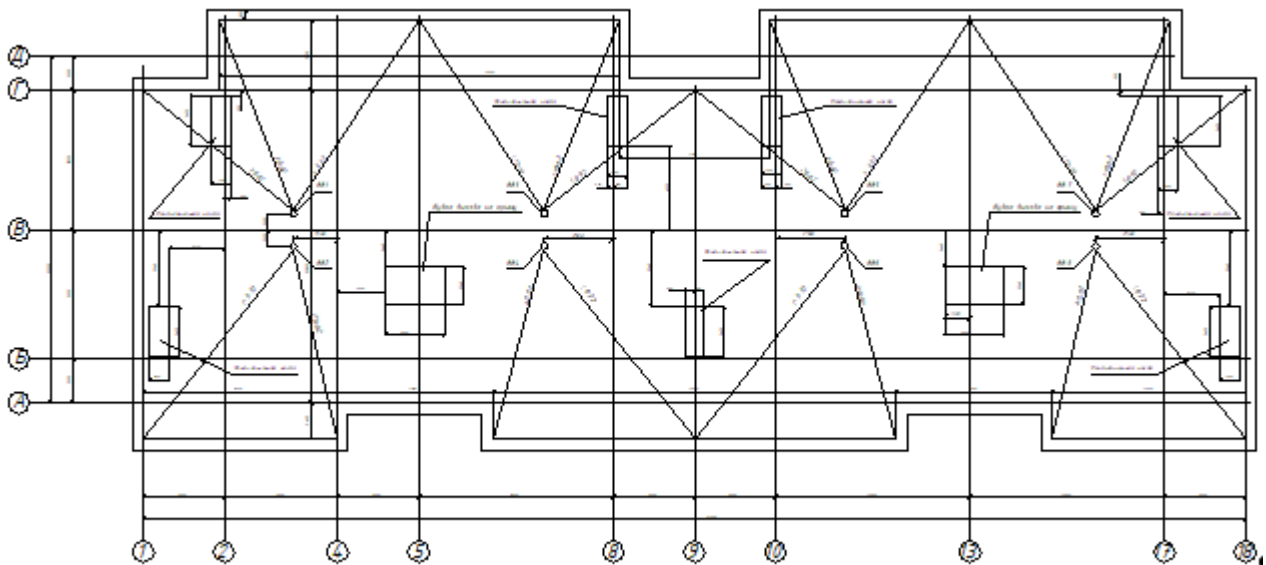

SCHEME 9

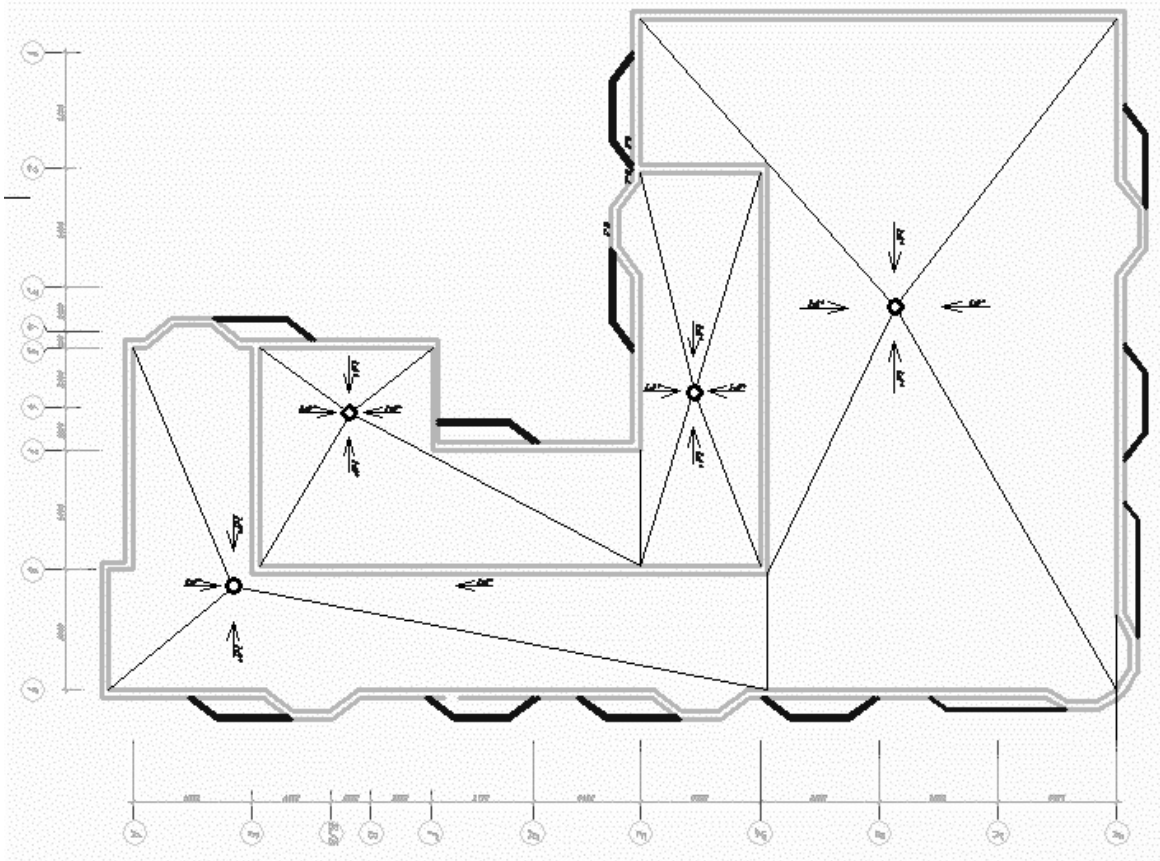

SCHEME 10

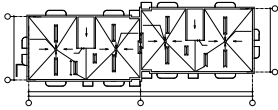

APPENDIX D. TABLE OF SELF-ASSESSMENT OF TECHNOLOGICAL MAP PERFORMANCE

Table D.1 – Requirements for the technological map

Requirement	Percentage weight
1	2
Explanatory note of 20-30 pages is made on one side of the numbered A4 sheets. The title page of the note is designed in the prescribed form. After the title page is the content of the note, assignments for the course project and introduction.	5 / ____
There is developed technological map in accordance with the task. It is allowed to combine information on different technological maps into one explanatory note (in each section - separately information on one and another map, while the graphic part is developed on separate sheets).	5 / ____
The explanatory note contains the following sections: Introduction. 1. Scope. 2. Organization and technology of works. 3. Calculation of labor costs and wages. 4. Calendar schedule of works. 5. Tables of material and technical resources needs. 6. Requirements for quality and acceptance of works. 7. Safety and labor protection, ecological and fire safety. 8. Technical and economic indicators. References.	5 / ____
The note is issued in accordance with the requirements of DSTU 3008: 2015. The note is made in English.	5 / ____
There are general data and characteristics of the object according to the data of the task for the course design.	5 / ____
The graphic part of the course project is performed on sheets of A1 format (in some cases - several sheets of A2 format), which show: 1. Scope of the technological map. 2. The scheme of production of works: the plan of object with breakdown on sites and captures, schemes of movement of workers and mechanisms. 3. Technological schemes, sequence of technological operations. 4. Calendar schedule of works. 5 Guidelines for quality control and acceptance of works. 6. Tables of material and technical resources needs. 7. Safety requirements. 8. Technical and economic indicators on the technological map.	8 / ____
The scheme of production of works is evenly divided into divisions according to - directive pace of work; - technological order of performance of works for various surfaces; - the most efficient use of divisions; - the procedure for performing work on the premises on the floor and the rational use of storage space.	8 / ____

Continuation of table D.1

1	2
<p>The note, according to the task, includes a description of the work on the arrangement of roofs:</p> <ul style="list-style-type: none"> - arrangement of a lattice; - installation of vapor barrier; - installation of thermal insulation; - arrangement of a lattice if necessary according to the task; - arrangement of the finishing layer of the roof according to the type in the task. 	10 / ____
<p>The calculation of labor costs is developed, which includes the nomenclature, technology and scope of work, time spent by workers and machine operators, division into technologies in accordance with the task, capture and work in accordance with the required pace of work, production scheme.</p>	10 / ____
<p>The schedule of works in the linear form corresponding to groups of division, the nomenclature and complexity of calculation of labor costs and the scheme of production of works is made. The schedule corresponds to the technological sequence of work. The total duration of work does not exceed 14 working days.</p>	10 / ____
<p>Compiled information needs separately for machines, mechanisms, tools and equipment to perform work. They correspond in their nomenclature to the accepted technology of work, and in quantitative terms - the division into grips and the number of simultaneously working workers.</p>	8 / ____
<p>The scheme of quality control of works is developed, including: measures on entrance, operational and reception control; controlled operations, control methods and relevant executive documentation.</p>	5 / ____
<p>Guidelines on labor protection and safety for all types of work on the basis of DBN A.3.3-2-2009 "System of labor safety standards. Industrial safety in construction".</p>	5 / ____
<p>Calculated and given technical and economic indicators in the composition of:</p> <ul style="list-style-type: none"> - Labor costs for the entire scope of work - Costs of machine time for the entire scope of work - Wages of workers - Wages of mechanics - Duration of work - Production of one worker per shift - Labor costs per 1 m² of roof - Labor costs of drivers per 1 m² of roof - The cost of labor per 1 m² of roof 	8 / ____
<p>The list of used literature, among other things, includes regulations on the calculation of labor costs, quality control and labor protection. The list of literature is designed in accordance with the requirements of applicable regulations.</p>	5 / ____
<p>Total execution rate:</p>	100 / ____